

**YAMAHA**

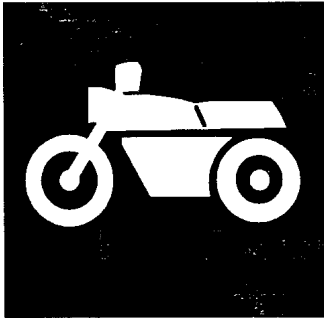

**PARTS  
CATALOGUE**

**WR200RG**

**WR200'95 (4BF4) ALL**

---

154BF-300E1

**YAMAHA**  
**GENUINE**  
Parts & Accessories



**A3**

## FOREWORD

This Parts Catalogue is related to the parts for the model(s) in the below frame. When you are ordering replacement parts, please refer to this Parts Catalogue and quote both part numbers and part names correctly.

WR200RG / WR200'95 (4BF4)

1. Modifications or additions which have been made after issue of the Parts Catalogue will be announced in the Yamaha Parts News.  
It is advisable that you make necessary corrections to the Parts Catalogue according to the Yamaha Parts News.

2. Abbreviations  
The following abbreviations are used in this Parts Catalogue.

"UR" Use specified parts number.  
 "UN" Use as many as needed.  
 "AP" Alternate Parts  
 "LM" Local Made (Parts need to be ordered locally)  
 "F#" Frame No. (Applicable machine No.)

3. Parts, which are to be supplied in an assembly, are listed with a dot (.) in front of the part name as shown below.

**EXAMPLE**

. CARBURETOR ASSY  
 . JET, PILOT  
 . NOZZLE, MAIN

4. Number of component for assembly  
The numeral appearing to the right of each component part indicates the quantity of parts for each assembly unit.

**EXAMPLE**

PART NO.	DESCRIPTION	Q'TY	REMARKS
2F5-83310-60	FRONT FLASHER LIGHT ASSY	2	
115-83311-60	. BULB (6V-18W)	1	

5. Applicable colors of graphics are represented in the "REMARKS" as shown below.

PART NO.	DESCRIPTION	Q'TY	REMARKS
2N4-24110-00-X5	FUEL TANK COMP.	1	MAXIM RED
3J1-24240-10	. GRAPHIC, FUEL TANK	1	for MXR

6. Applicable Serial No. and Color Code

① Frame Serial No.	4BF-012101	~
② Engine Serial No.	4BF-012101	~

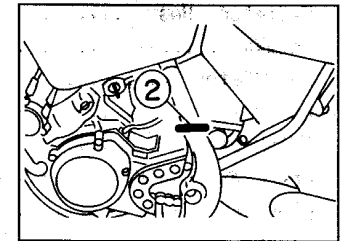
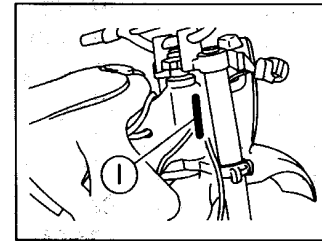

Color Code	Color Name	Abbreviation
0206	PURPRISH WHITE SOLID 1	PWS1

7. Note that the illustrations are for reference in finding parts numbers, not to be used for assembling. When assembling, please use the applicable service manual.

8. The asterisk (\*) before a reference number indicates modification items after the first edition.

A4

# CONTENTS

## ENGINE

Cylinder .....	B2~B3
Crankshaft. Piston .....	B4~B5
Water Pump .....	B6
Radiator. Hose .....	B7~B8
Intake .....	B9~B10
Carburetor .....	B11~B12
Exhaust .....	B13
Crankcase .....	B14
Crankcase Cover 1 .....	B15
Starter .....	C2
Clutch .....	C3~C4
Transmission .....	C5~C6
Shift Cam. Fork .....	C7
Shifter .....	C8

Rear Brake Caliper .....	D11
Steering Handle. Cable .....	D12
Front Master Cylinder .....	D13
Stand. Footrest .....	D14
Rear Master Cylinder .....	D15
Generator .....	E2
Meter .....	E3
Headlight .....	E4
Taillight .....	E5
Handle Switch. Lever .....	E6
Electrical 1 .....	E7

## CHASSIS

Frame .....	C9
Fender .....	C10
Side Cover .....	C11~C12
Oil Tank .....	C13
Rear Arm .....	C14~C15
Rear Suspension .....	D2
Steering .....	D3
Front Fork .....	D4~D5
Fuel Tank .....	D6
Seat .....	D7
Front Wheel .....	D8
Front Brake Caliper .....	D9
Rear Wheel .....	D10

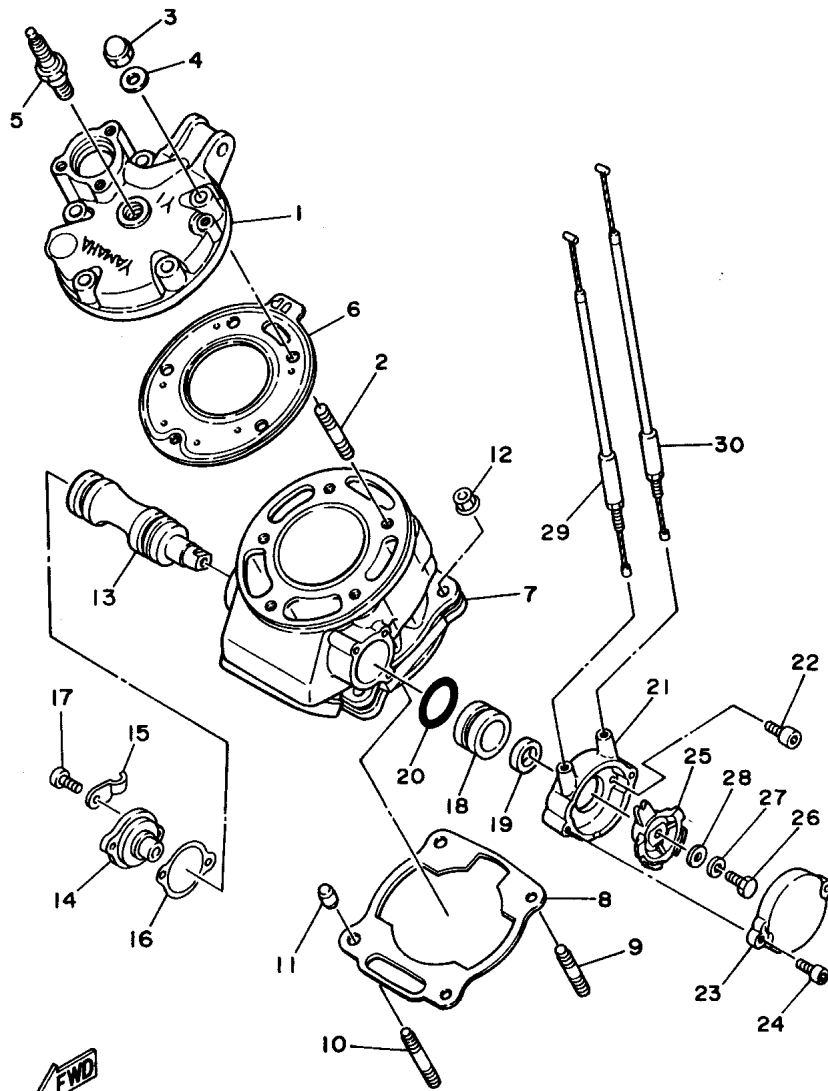

3XP1010-1010

FIG. 1 CYLINDER

REF. NO.	PART NO.	DESCRIPTION	Q'TY	REMARKS
1	3XP-11111-00	HEAD, CYLINDER 1	1	
2	90116-08394	BOLT, STUD	5	
3	90176-08040	NUT, CROWN	5	
4	90201-08649	WASHER, PLATE	5	
5	94701-00188	PLUG, SPARK (NGK BR9ES)	1	
6	3XP-11181-00	GASKET, CYLINDER HEAD 1	1	
7	3XP-11311-00	CYLINDER 1	1	
8	3XP-11351-00	GASKET, CYLINDER	1	
9	90116-08318	BOLT, STUD	2	
10	90116-08388	BOLT, STUD	2	
11	99510-10114	PIN, DOWEL	2	
12	90179-08491	NUT	4	
13	3XP-1131A-00	VALVE 1	1	
14	3RR-1131E-00	HOLDER 1	1	
15	90462-08201	CLAMP	1	
16	4FL-1131N-00	GASKET, HOLDER	1	
17	91317-05012	BOLT	2	
18	31K-1131U-00	HOLDER 3	1	
19	93108-23010	OIL SEAL	1	
20	93210-30734	O-RING	1	
21	2RH-1131M-10	COVER	1	
22	91317-05010	BOLT	2	
23	2RH-1131R-10	CAP, SEAL	1	
24	91317-05012	BOLT	2	
25	29L-1132E-00	PULLEY 1	1	
26	97027-06018	BOLT	1	
27	92907-06100	WASHER, SPRING	1	
28	92907-06600	WASHER, PLATE	1	

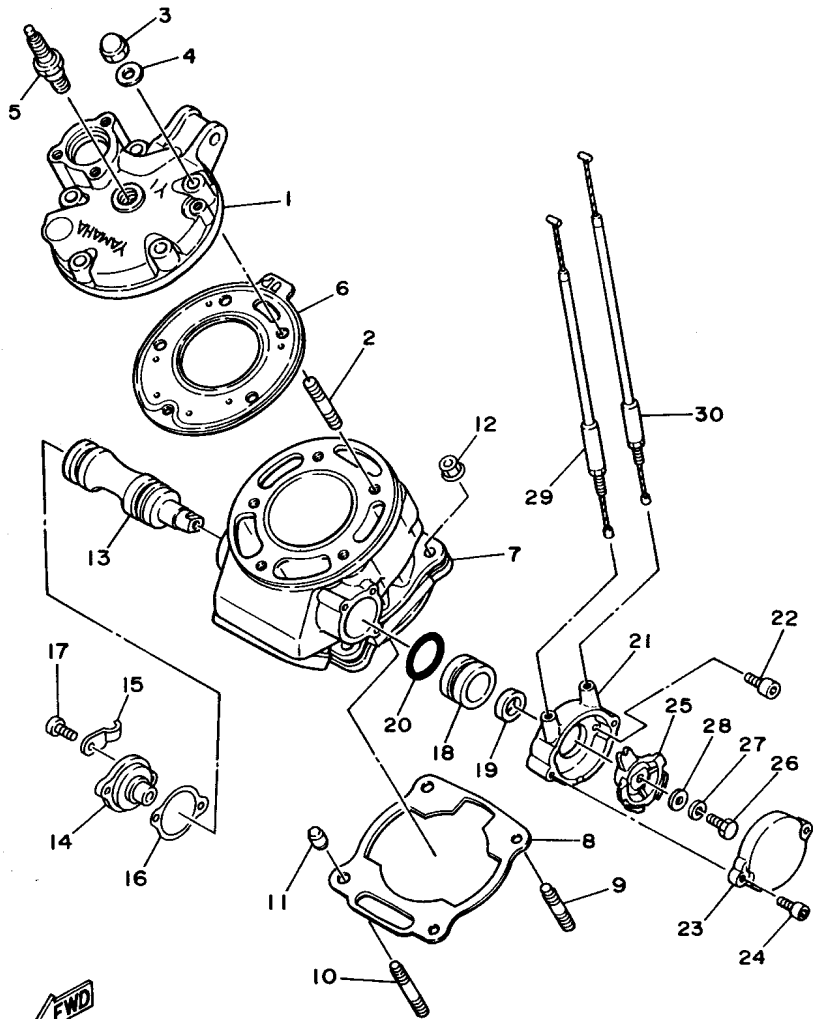

FIG. 1 CYLINDER

REF. NO.	PART NO.	DESCRIPTION	Q'TY	REMARKS
29	3XP-1133E-00	CABLE, PULLEY 1	1	
30	3BN-1133F-00	CABLE, PULLEY 2	1	



3XP1010-1010

**B3**

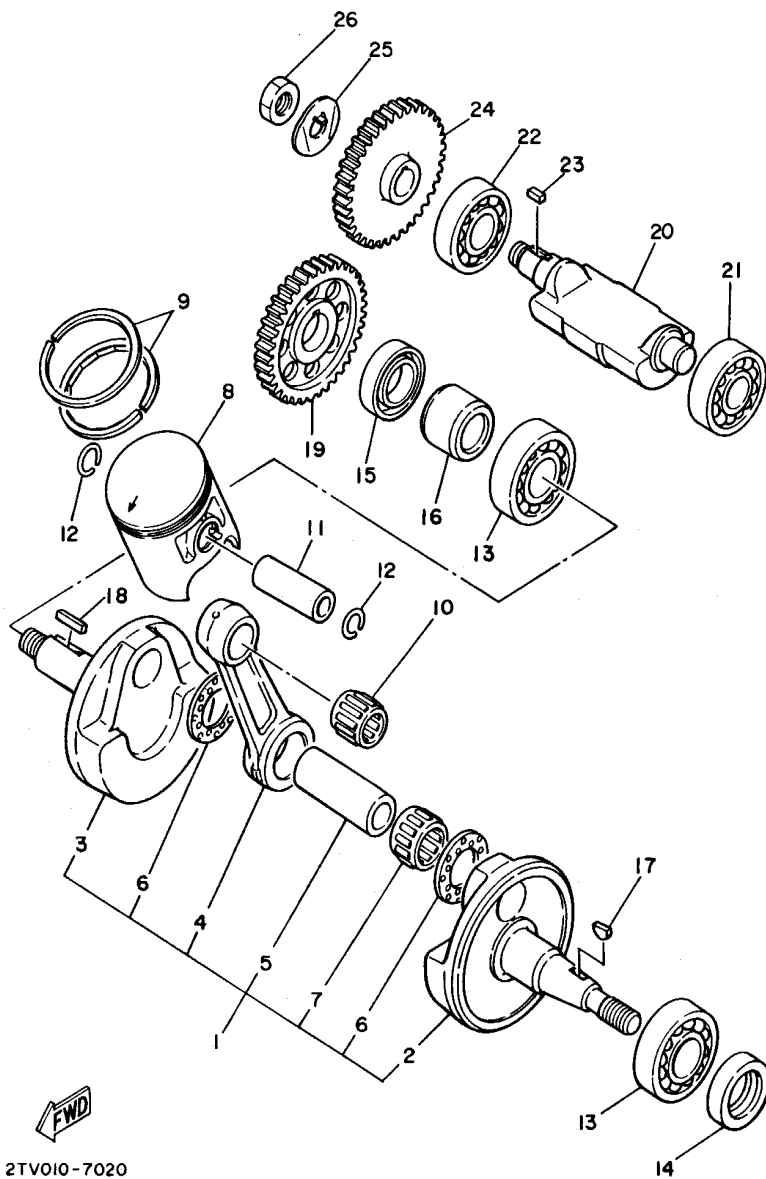

2TV010-7020

FIG. 2 CRANKSHAFT. PISTON

REF. NO.	PART NO.	DESCRIPTION	Q'TY	REMARKS
1	3XP-11400-00	CRANKSHAFT ASSY	1	
2	3XP-11412-00	.CRANK 1	1	
3	3XP-11422-00	.CRANK 2	1	
4	43G-11651-00	.ROD, CONNECTING	1	
5	37F-11681-00	.PIN, CRANK 1	1	
6	90209-22257	.WASHER	2	
7	93310-52302	.BEARING, CYLINDRICAL	1	
8	3XP-11631-01-A0	PISTON (STD)	1	UR RED
	3XP-11631-01-B0	PISTON (STD)	1	UR ORANGE
	3XP-11631-01-C0	PISTON (STD)	1	UR GREEN
	3XP-11631-01-D0	PISTON (STD)	1	UR PURPLE
9	3XP-11610-00	PISTON RING SET (STD)	1	
10	93310-316C9	BEARING, CYLINDRICAL	1	
11	4H7-11633-00	PIN, PISTON	1	
12	93450-17129	CIRCLIP	2	
13	93306-30556	BEARING	2	
14	93102-25331	OIL SEAL	1	
15	93103-32099	OIL SEAL	1	
16	90387-202T9	COLLAR	1	
17	90280-03017	KEY, WOODRUFF	1	
18	90282-05047	KEY, STRAIGHT	1	
19	10V-11536-01	GEAR, DRIVE	1	
20	2TV-11454-00	WEIGHT 1	1	
21	93306-30210	BEARING	1	
22	93306-20335	BEARING	1	
23	90282-05058	KEY, STRAIGHT	1	
24	55K-11530-00	BALANCER WIEGHT GEAR COMP.43T	1	
25	90215-12272	WASHER, LOCK	1	

B4

FIG. 2 CRANKSHAFT. PISTON

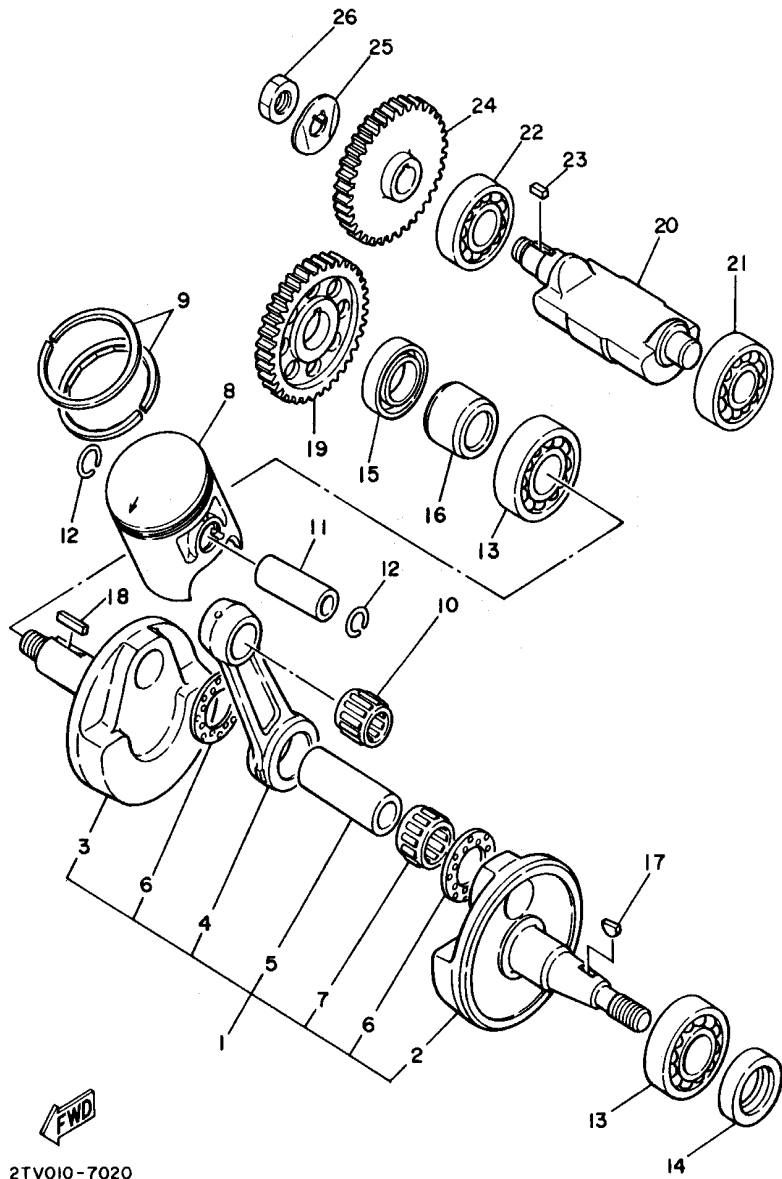

REF. NO.	PART NO.	DESCRIPTION	Q'TY	REMARKS
26	90170-12370	NUT	1	

2TV010-7020

**B5**



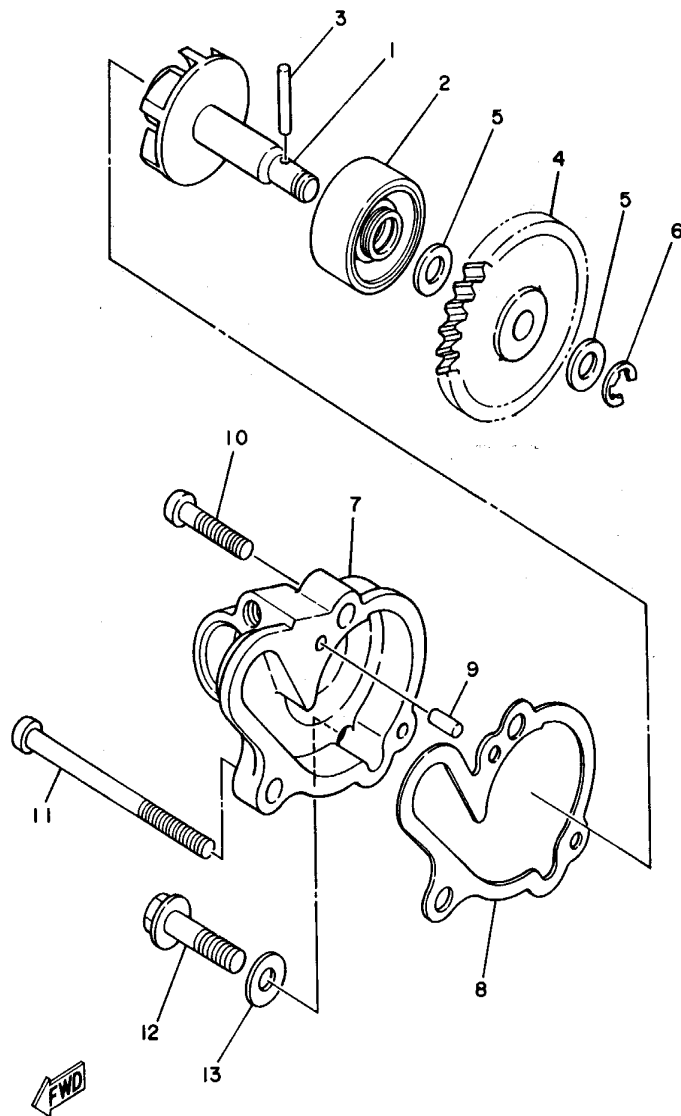

3XP3010-2030

FIG. 3 WATER PUMP

REF. NO.	PART NO.	DESCRIPTION	Q'TY	REMARKS
1	36F-12450-00	IMPELLER SHAFT ASSY *	1	
2	93103-10168	OIL SEAL	1	
3	93603-22028	PIN, DOWEL	1	
4	2TV-12459-00	GEAR, IMPELLER SHAFT	1	
5	90201-08512	WASHER, PLATE	2	
6	99080-07600	CIRCLIP	1	
7	3XP-12422-10	COVER, HOUSING	1	
8	3BN-12428-11	GASKET, HOUSING COVER 2	1	
9	93604-10011	PIN, DOWEL	2	
10	98507-06025	SCREW, PAN HEAD	1	
11	98507-06065	SCREW, PAN HEAD	1	
12	95827-06025	BOLT, FLANGE	1	
13	90430-06166	GASKET	1	

**B6**

FIG. 4 RADIATOR. HOSE

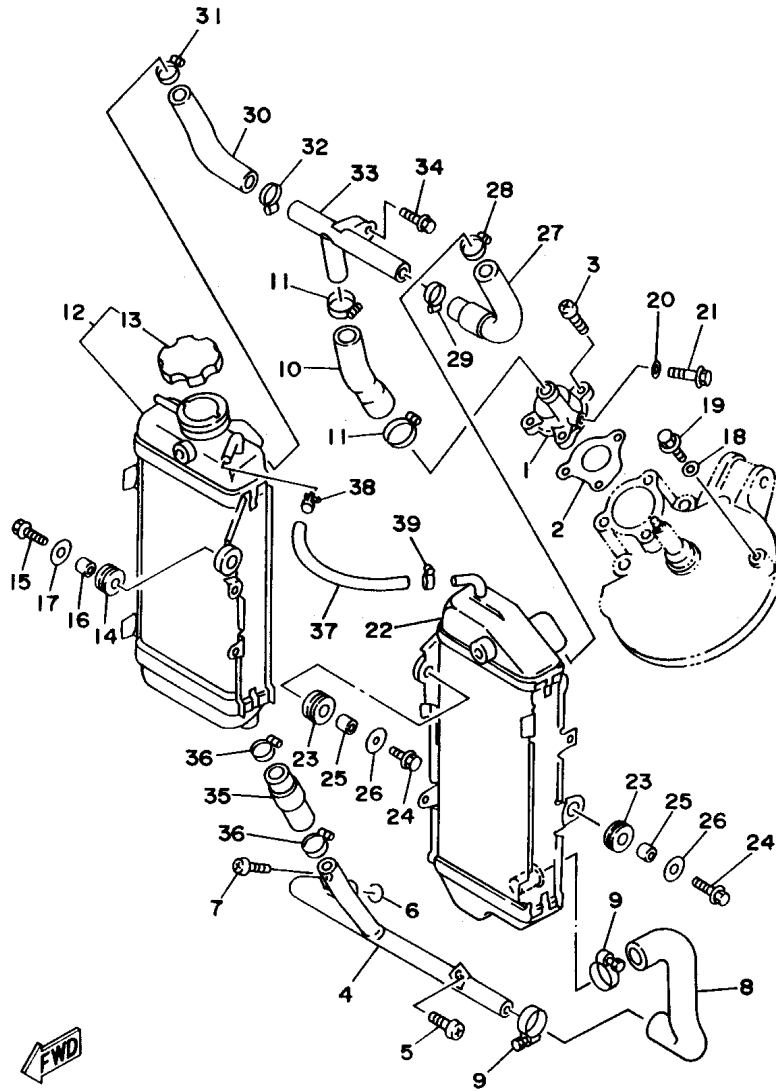

4BF2100-3040

REF. NO.	PART NO.	DESCRIPTION	Q'TY	REMARKS
1	3BN-12469-00	JOINT 1	1	
2	3BN-12414-10	GASKET, COVER	1	
3	98517-06020	SCREW, PAN HEAD	3	
4	3XP-12481-10	PIPE 1	1	
5	98507-06012	SCREW, PAN HEAD	1	
6	93210-16500	O-RING	1	
7	98507-06012	SCREW, PAN HEAD	1	
8	3XP-12482-10	PIPE 2	1	
9	90450-28014	HOSE CLAMP ASSY	2	
10	3XP-12483-10	PIPE 3	1	
11	90450-28014	HOSE CLAMP ASSY	2	
12	3XP-12460-00	RADIATOR ASSY	1	
13	3XP-12462-00	CAP, RADIATOR	1	
14	90480-18276	GROMMET	2	
15	95027-06025	BOLT, FLANGE	2	
16	90387-07573	COLLAR	2	
17	90201-063J2	WASHER, PLATE	2	
18	90430-06166	GASKET	1	
19	95817-06010	BOLT, FLANGE	1	
20	90430-06166	GASKET	1	
21	95817-06010	BOLT, FLANGE	1	
22	4BF-1240A-10	RADIATOR ASSY 2	1	
23	90480-15064	GROMMET	2	
24	95027-06025	BOLT, FLANGE	2	
25	90387-07392	COLLAR	2	
26	90201-063J2	WASHER, PLATE	2	
27	3XP-12484-10	PIPE 4	1	
28	90450-22052	HOSE CLAMP ASSY	1	

B7

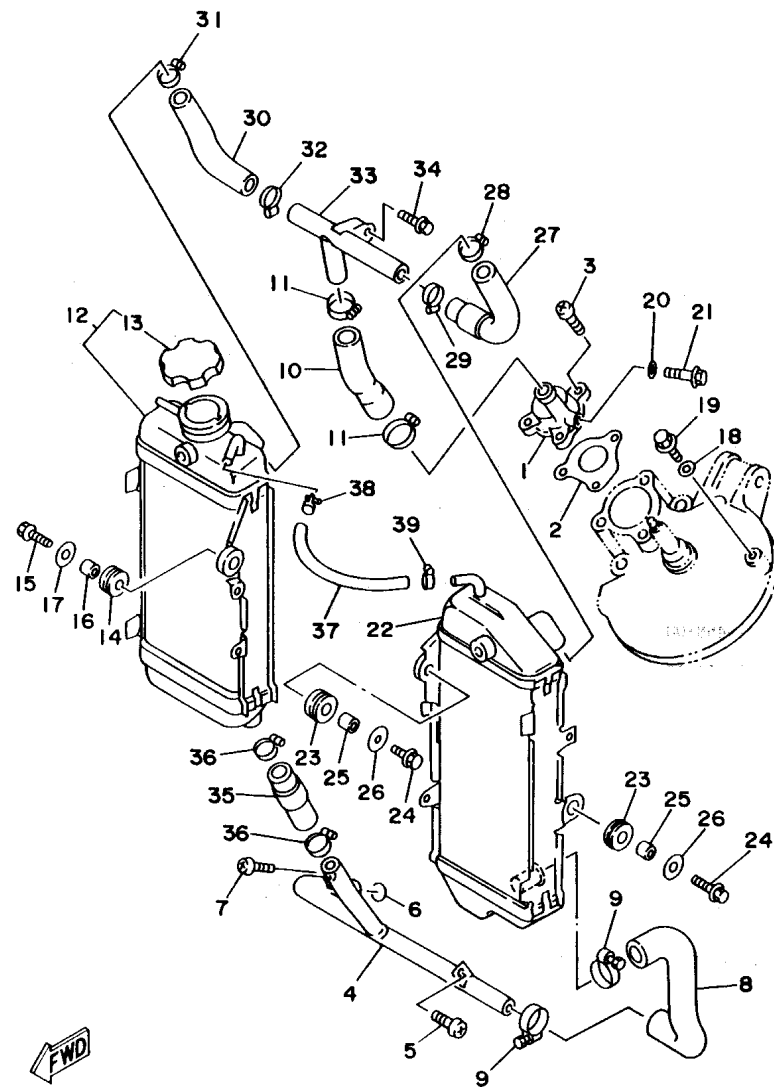

4BF2100-3040

FIG. 4 RADIATOR. HOSE

REF. NO.	PART NO.	DESCRIPTION	Q'TY	REMARKS
29	90450-28014	HOSE CLAMP ASSY	1	
30	3XP-12485-10	PIPE 5	1	
31	90450-22052	HOSE CLAMP ASSY	1	
32	90450-28014	HOSE CLAMP ASSY	1	
33	3XP-12469-10	JOINT 1	1	
34	95807-06010	BOLT, FLANGE	1	
35	3XP-12476-10	PIPE 6	1	
36	90450-22052	HOSE CLAMP ASSY	2	
37	1LX-1248A-00	PIPE 8	1	
38	90450-15041	HOSE CLAMP ASSY	1	
39	90450-17036	HOSE CLAMP ASSY	1	

**B8**

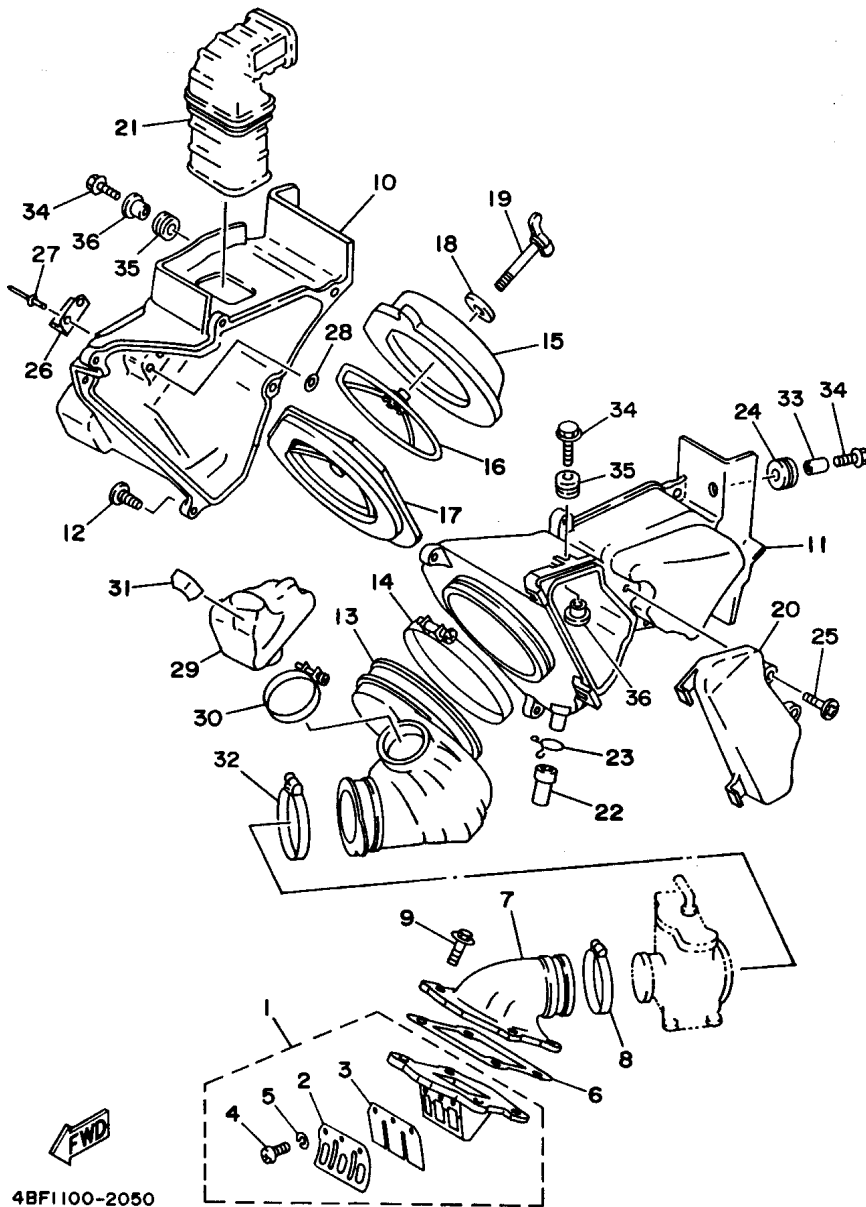

48F1100-2050

FIG. 5 INTAKE

REF. NO.	PART NO.	DESCRIPTION	Q'TY	REMARKS
1	1LX-13610-01	REED VALVE ASSY	1	
2	55Y-13613-00	.REED, VALVE	2	
3	55Y-13616-00	.STOPPER, REED VALVE	2	
4	98507-03008	.SCREW, PAN HEAD	6	
5	92990-03100	.WASHER, SPRING	6	
6	3XP-13621-00	GASKET, VALVE SEAT	1	
7	3XP-13565-00	JOINT, CARBURETOR	1	
8	90450-49020	HOSE CLAMP ASSY	1	
9	95027-06020	BOLT, FLANGE	4	
10	3XP-14411-00	CASE, AIR CLEANER 1	1	
11	3XP-14421-00	CASE, AIR CLEANER 2	1	
12	97707-50520	SCREW, TAPPING	7	
13	3XP-14453-00	JOINT, AIR CLEANER 1	1	
14	90450-99013	HOSE CLAMP ASSY	1	
15	48F-14451-00	ELEMENT, AIR CLEANER	1	
16	3XP-14458-00	GUIDE	1	
17	3XP-14459-00	HOLDER, GUIDE	1	
18	90209-06096	WASHER	1	
19	90122-06013	BOLT, WING	1	
20	3XP-14412-00	CAP, CLEANER CASE 1	1	
21	3XP-14437-00	DUCT	1	
22	3AJ-1443E-00	PIPE, DRAIN	1	
23	90467-15012	CLIP	1	
24	90480-08216	GROMMET	1	
25	90149-06200	SCREW	2	
26	43G-14436-00	HOOK	2	
27	90267-40080	RIVET, BLIND	4	
28	92907-04600	WASHER, PLATEE	4	

**B9**

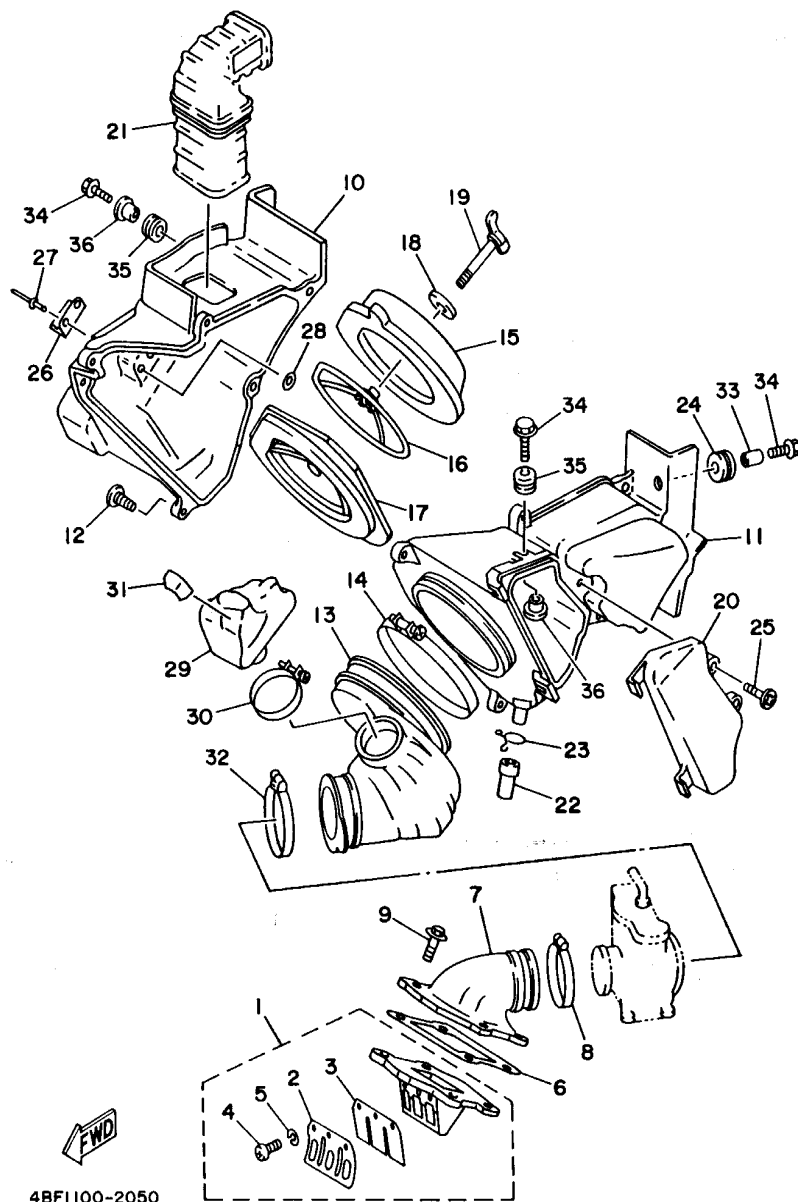
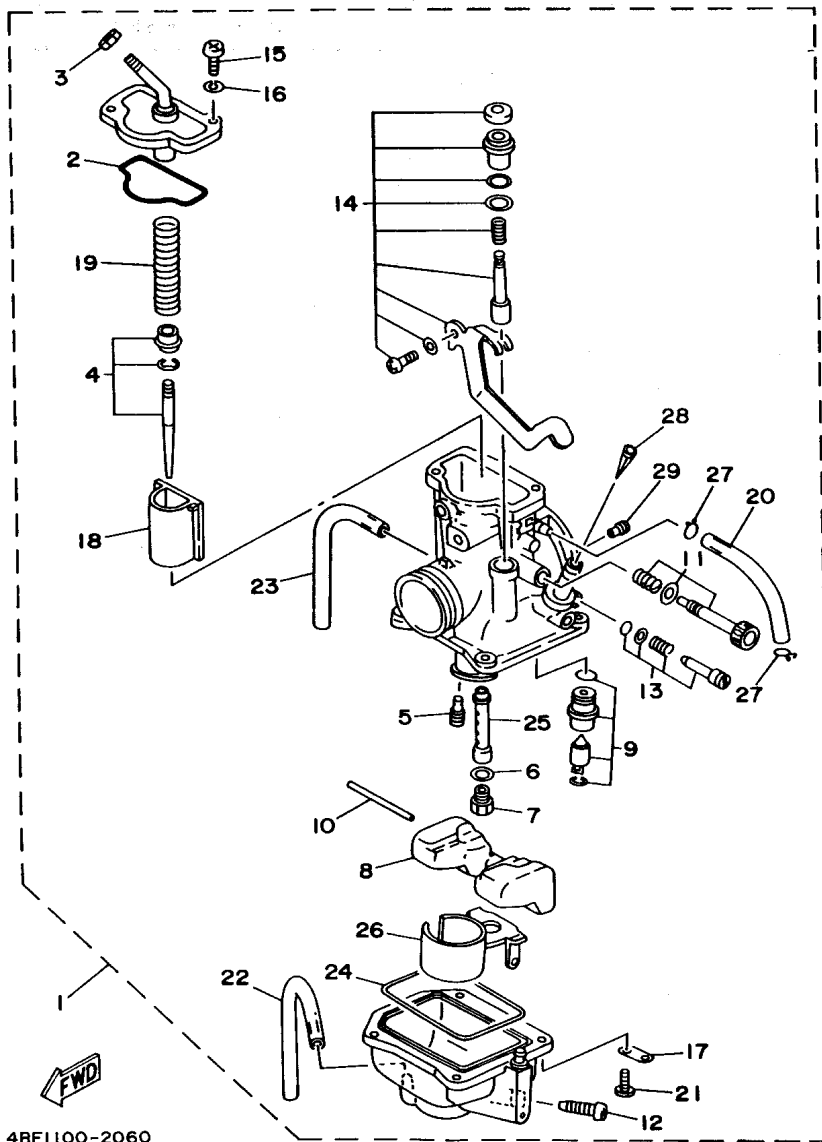

FIG. 5 INTAKE

REF. NO.	PART NO.	DESCRIPTION	Q'TY	REMARKS
29	3XP-13591-00	CHAMBER, AIR 2	1	
30	90460-32182	CLAMP, HOSE	1	
31	1AE-2834F-00	DAMPER	1	
32	90460-61063	CLAMP, HOSE	1	
33	90387-06241	COLLAR	1	
34	90119-06118	BOLT, WITH WASHER	3	
35	90480-12067	GROMMET	2	
36	90387-06737	COLLAR	2	



4BF1100-2060

FIG. 6 CARBURETOR

REF. NO.	PART NO.	DESCRIPTION	Q'TY	REMARKS
1	4BF-14101-00	CARBURETOR ASSY 1	1	
2	3JD-14147-00	.O-RING	1	
3	127-14161-00	.NUT, CABLE ADJUSTING	1	
4	3XP-1490J-10	.NEEDLE SET	1	
5	193-14142-35	.JET, PILOT (#35)	1	
6	137-14153-00	.WASHER, MAIN JET	1	
7	137-14143-42-A1	.JET, MAIN (#210)	1	
8	3XP-14185-00	.FLOAT	1	
9	3XP-14190-30	.NEEDLE VALVE ASSY	1	
10	353-14186-00	.PIN, FLOAT	1	
11	3XP-14103-00	.THROTTLE SCREW SET	1	
12	12R-14191-00	.PLUG, DRAIN	1	
13	3XP-14104-00	.AIR SCREW SET	1	
14	3XP-1410A-00	.STARTER SET	1	
15	98511-04012	.SCREW, PAN HEAD	2	
16	92902-04100	.WASHER, SPRING	2	
17	313-14146-00	.PLATE	2	
18	3XP-14112-40	.VALVE, THROTTLE 1	1	
19	3XP-14931-00	.SPRING, THROTTLE LEVER	1	
20	3XP-14294-00	.HOSE	1	
21	98580-05014	.SCREW, PAN HEAD	4	
22	3KD-14197-00	.PIPE	1	
23	3XG-14196-00	.PIPE	2	
24	3XP-14229-00	.SEAL	1	
25	3XP-14141-28	.NOZZLE, MAIN	1	
26	3XP-14261-00	.HOLDER	1	
27	8A7-14139-00	.CLIP, PIPE	2	
28	1KT-14994-00	.NET, FILTER	1	

**B11**

FIG. 6 CARBURETOR

REF. NO.	PART NO.	DESCRIPTION	Q'TY	REMARKS
29	239-14172-08	.PILOT JET, AIR (0.8)	1	

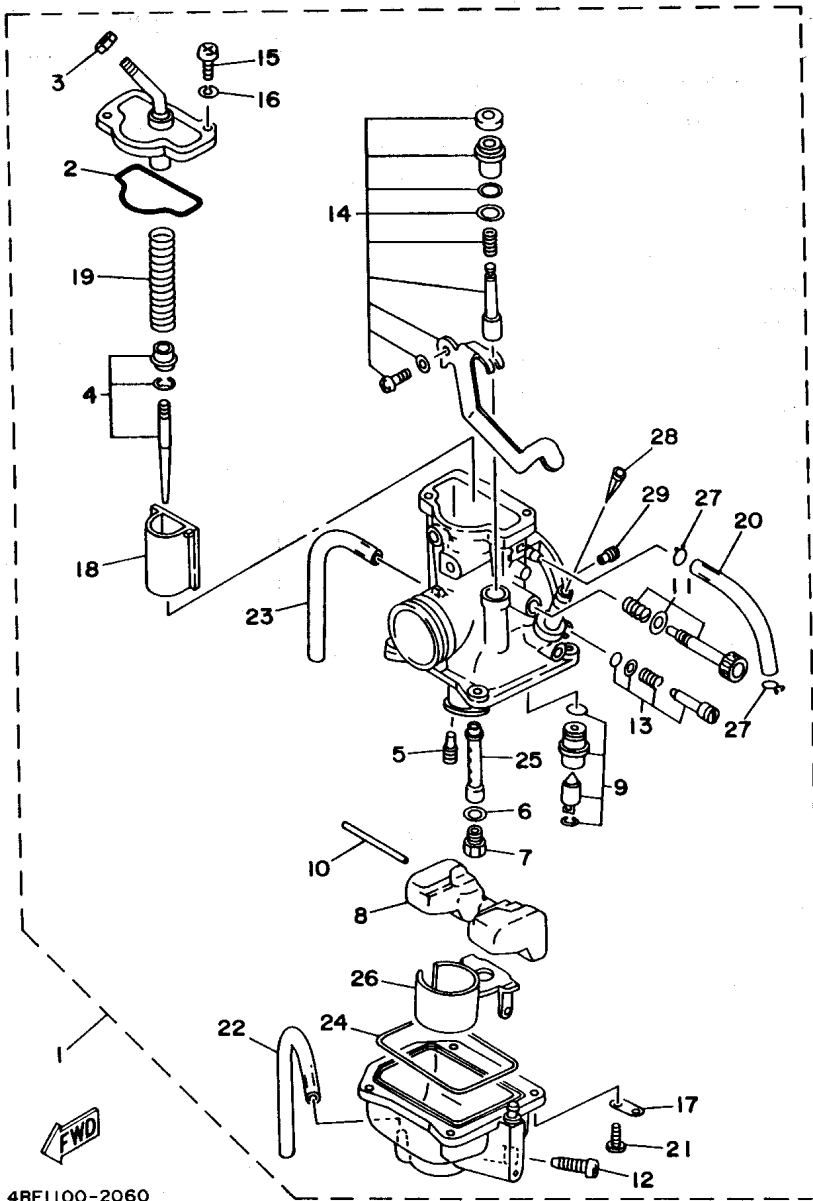

4BF1100-2060

**B12**

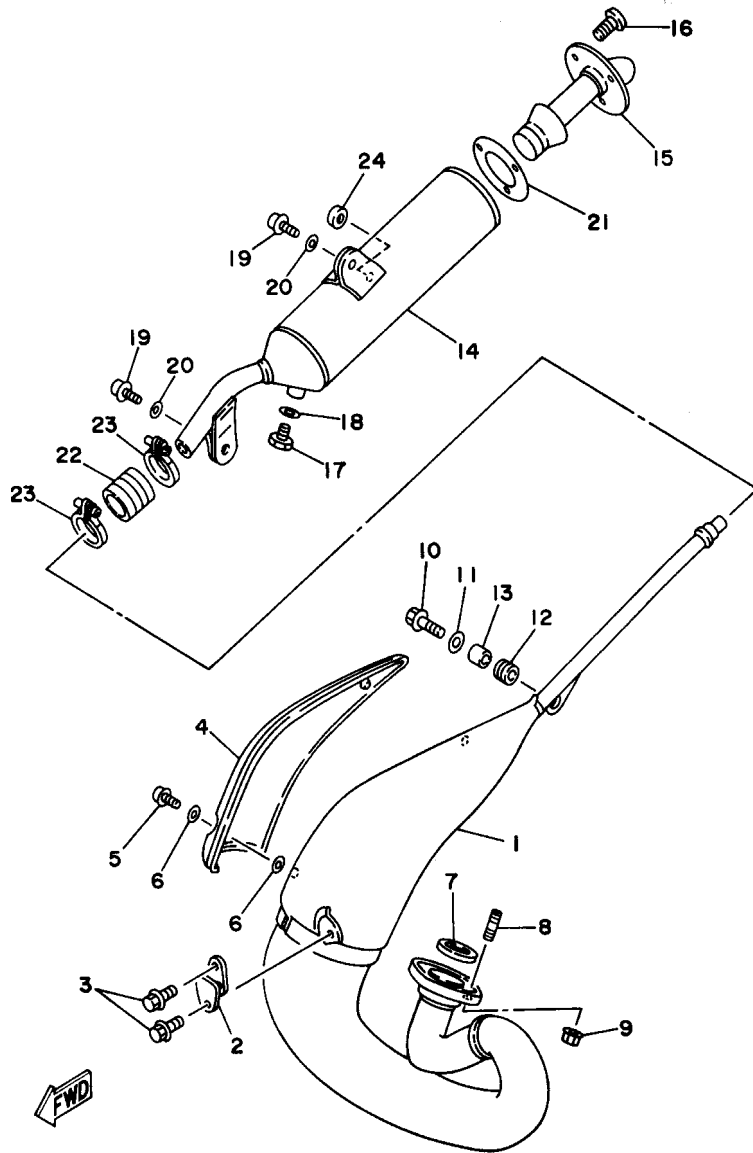

1BF1100-2070

FIG. 7 EXHAUST

REF. NO.	PART NO.	DESCRIPTION	Q'TY	REMARKS
1	3XP-14610-00	EXHAUST PIPE ASSY 1	1	
2	565-14771-00	STAY, MUFFLER 1	1	
3	95817-06012	BOLT, FLANGE	2	
4	3XP-14718-00	PROTECTOR, MUFFLER 1	1	
5	98907-06010	SCREW, BIND	2	
6	90202-05187	WASHER, PLATE	4	
7	3PA-14613-10	GASKET, EXHAUST PIPE	1	
8	90116-08042	BOLT, STUD	2	
9	90179-08270	NUT	2	
10	95827-06025	BOLT, FLANGE	1	
11	90201-060A3	WASHER, PLATE	1	
12	90480-18411	GROMMET	1	
13	90387-105L0	COLLAR	1	
14	4BF-14753-00	SILENCER, EXHAUST	1	
15	2GU-14752-00	PIPE, OUTLET	1	
16	98907-06010	SCREW, BIND	3	
17	90101-06576	BOLT	1	
18	92907-06600	WASHER, PLATE	1	
19	90109-085E2	BOLT	2	
20	90201-08326	WASHER, PLATE	2	
21	2GU-14613-10	GASKET, EXHAUST PIPE	1	
22	3XP-14714-00	GASKET, MUFFLER	1	
23	90460-37026	CLAMP, HOSE	2	
24	157-27114-00	STOPPER, MAIN STAND	1	

B13



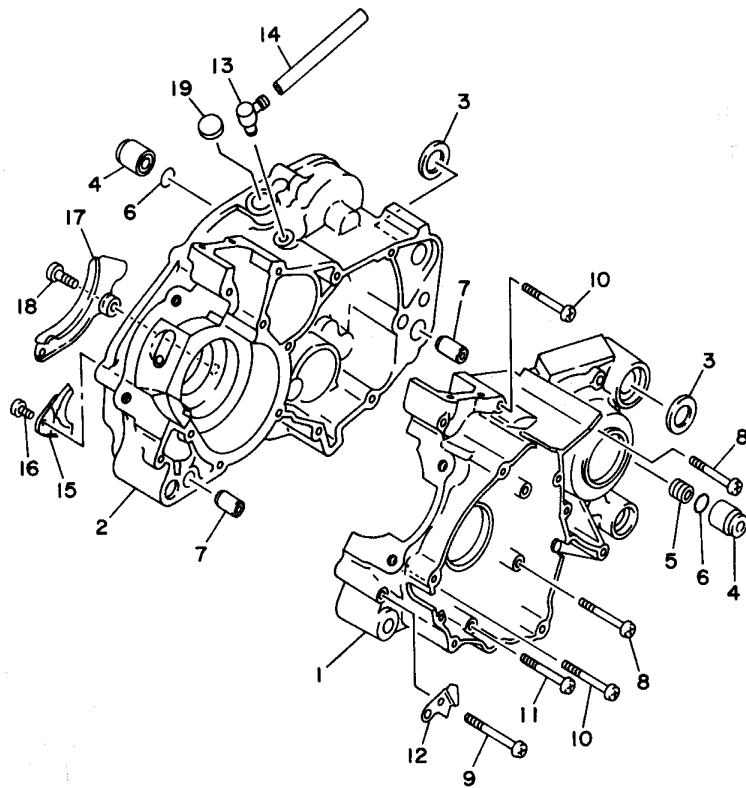

FIG. 8 CRANKCASE

REF. NO.	PART NO.	DESCRIPTION	Q'TY	REMARKS
1	3XP-15111-00	CRANKCASE 1	1	
2	3XP-15121-01	CRANKCASE 2	1	
3	90201-170M2	WASHER, PLATE	2	
4	328-15316-00	DAMPER, ENGINE MOUNT	2	
5	3XP-15317-00	SPACER, ENGINE MOUNT	1	
6	93210-11313	O-RING	2	
7	99510-12016	PIN, DOWEL	2	
8	98507-06060	SCREW, PAN HEAD	4	
9	98507-06065	SCREW, PAN HEAD	1	
10	98507-06050	SCREW, PAN HEAD	6	
11	98507-06070	SCREW, PAN HEAD	2	
12	3BN-15199-01	BRACKET	1	
13	583-15371-00	BREATHER	1	
14	90446-07349	HOSE	1	
15	37F-15128-00	HOLDER	1	
16	98507-08010	SCREW, PAN HEAD	1	
17	2RH-15492-00	COVER	1	
18	98507-06012	SCREW, PAN HEAD	2	
19	90338-16029	PLUG	1	



3XP1010-1090

**B14**

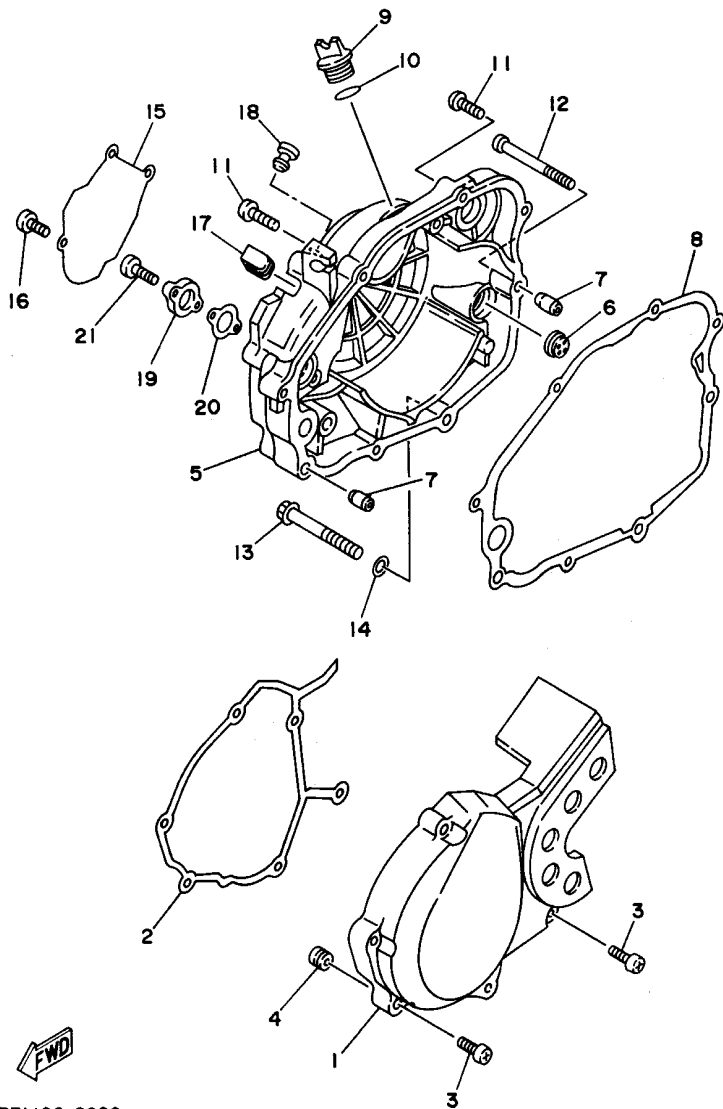

FIG. 9 CRANKCASE COVER 1

REF. NO.	PART NO.	DESCRIPTION	Q'TY	REMARKS
1	3BN-15411-11	COVER, CRANKCASE 1	1	
2	3ET-15379-00	SEAL, CRANKCASE	1	
3	90157-06115	SCREW, PAN HEAD	6	
4	90480-09481	GROMMET	6	
5	3XP-15421-01	COVER, CRANKCASE 2	1	
6	3Y1-15361-00	GAUGE, LEVEL	1	
7	99530-10014	PIN, DOWEL	2	
8	3XP-15451-00	GASKET, CRANKCASE COVER 1	1	
9	1RG-15363-00	PLUG, OIL	1	
10	93210-19123	O-RING	1	
11	98507-06030	SCREW, PAN HEAD	5	
12	98507-06040	SCREW, PAN HEAD	1	
13	95807-08080	BOLT, FLANGE	1	
14	90201-08087	WASHER, PLATE	1	
15	4BF-15416-00	COVER, OIL PUMP	1	
16	98507-06012	SCREW, PAN HEAD	3	
17	4BF-15357-00	GROMMET	1	
18	4BF-15189-00	PLUG	1	
19	161-15426-00	COVER, PUMP UNIT	1	
20	126-13116-01	GASKET, PUMP CASE	1	
21	98507-05014	SCREW, PAN HEAD	2	

4BF1100-2090

**B15**

FIG. 10 STARTER

REF. NO.	PART NO.	DESCRIPTION	Q'TY	REMARKS
1	10V-15660-00	KICK AXLE ASSY	1	
2	10V-15641-00	GEAR, KICK (23T)	1	
3	90468-26048	CLIP	1	
4	90201-200J7	WASHER, PLATE	1	
5	90508-26667	SPRING, TORSION	1	
6	10V-15666-00	SPACER	1	
7	10V-15651-00	GEAR, KICK IDLE (29T)	1	
8	90201-154E8	WASHER, PLATE	2	
9	99009-15400	CIRCLIP	2	
10	3XP-15620-01	KICK CRANK ASSY	1	
11	3XP-15621-00	.BOSS, KICK CRANK	1	
12	90501-12081	.SPRING, COMPRESSION	1	
13	93507-32031	.BALL	1	
14	90201-12631	.WASHER, PLATE	1	
15	93430-08007	.CIRCLIP	1	
16	90179-12659	NUT	1	
17	93102-20309	OIL SEAL	1	

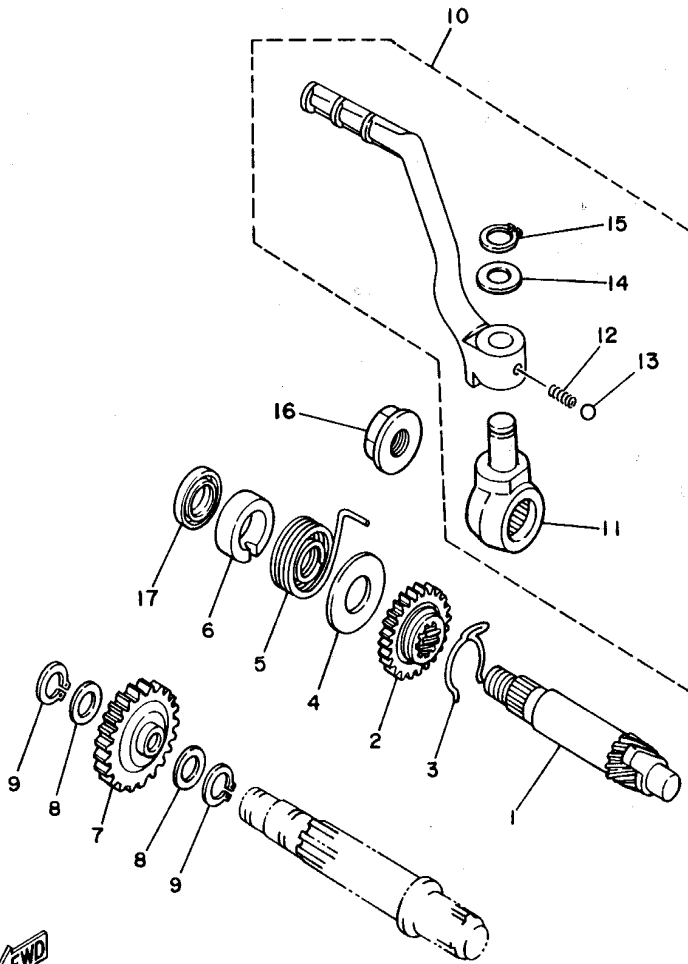

3XP1010-1110

C2

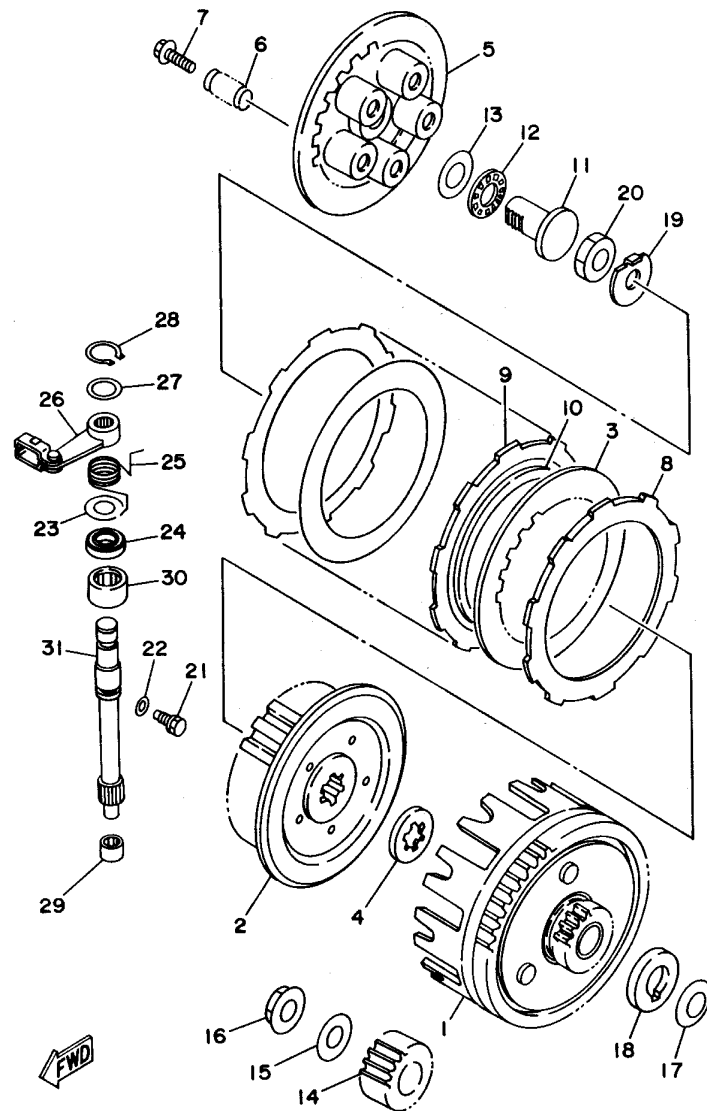

3XP1010-1120

FIG. 11 CLUTCH

REF. NO.	PART NO.	DESCRIPTION	Q'TY	REMARKS
1	3XP-16150-00	PRIMARY DRIVEN GEAR COMP.	1	
2	2TV-16371-00	BOSS, CLUTCH	1	
3	1V1-16324-00	PLATE, CLUTCH 1	6	
4	2TV-16154-00	PLATE, THRUST 1	1	
5	3XP-16351-00	PLATE, PRESSURE 1	1	
6	90501-20568	SPRING, COMPRESSION	5	
7	90119-05001	BOLT, WITH WASHER	5	
8	21V-16321-00	PLATE, FRICTION	6	
9	1HX-16331-00	PLATE, FRICTION 2	1	
10	3BN-16383-00	SPRING, CLUTCH BOSS	1	
11	3LD-1637A-01	ROD PUSH ASSY	1	
12	93340-21505	BEARING, THRUST	1	
13	90201-150H2	WASHER, PLATE	1	
14	3RR-16111-00	GEAR, PRIMARY DRIVE	1	
15	90201-120E8	WASHER, PLATE	1	
16	90179-12659	NUT	1	
17	90208-18046	WASHER, CONICAL SPRING	1	
18	90201-180P2	WASHER, PLATE	1	
19	90215-12271	WASHER, LOCK	1	
20	90170-12370	NUT	1	
21	90109-06418	BOLT	1	
22	90430-06014	GASKET	1	
23	90201-12474	WASHER, PLATE	1	
24	93102-15212	OIL SEAL	1	
25	90508-14767	SPRING, TORSION	1	
26	3VD-16340-11	PUSH LEVER ASSY	1	
27	90201-10119	WASHER, PLATE	1	
28	99009-10400	CIRCLIP	1	

C3

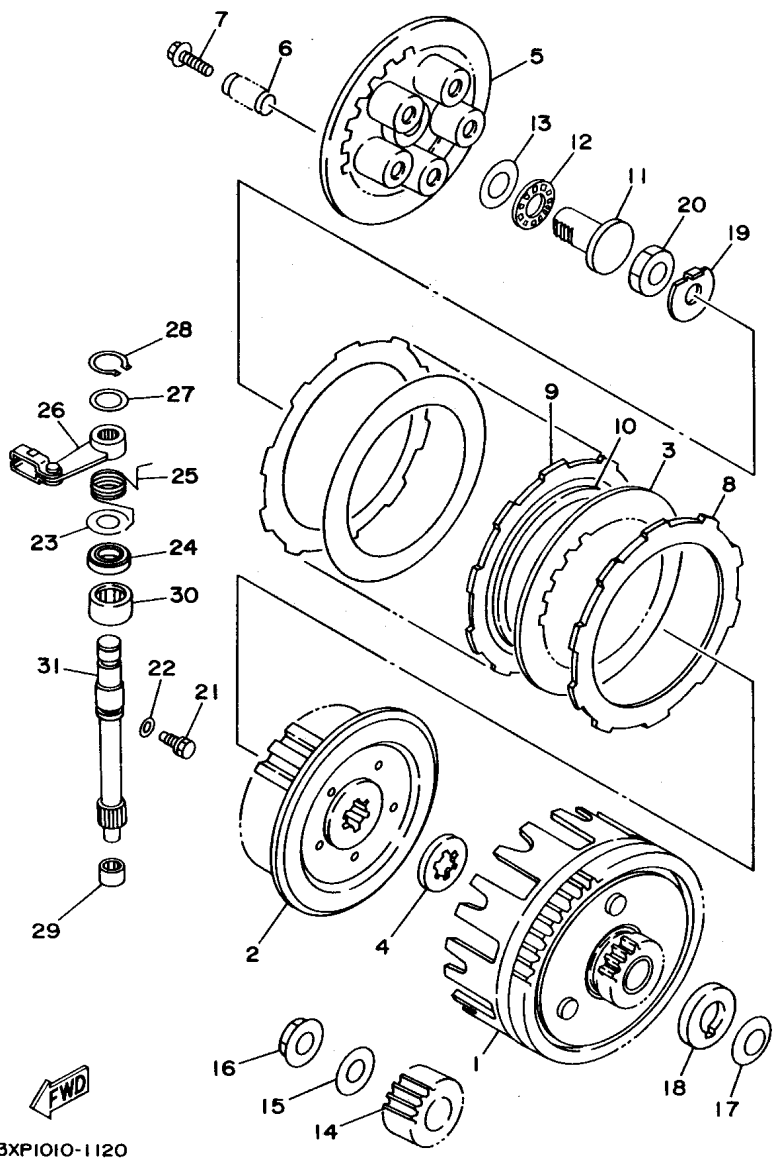

3XP1010-1120

FIG. 11 CLUTCH

REF. NO.	PART NO.	DESCRIPTION	Q'TY	REMARKS
29	93315-10838	BEARING, CYLINDRICAL	1	
30	93315-31502	BEARING, CYLINDRICAL	1	
31	3JD-16382-00	AXLE, PUSH LEVER	1	

C4

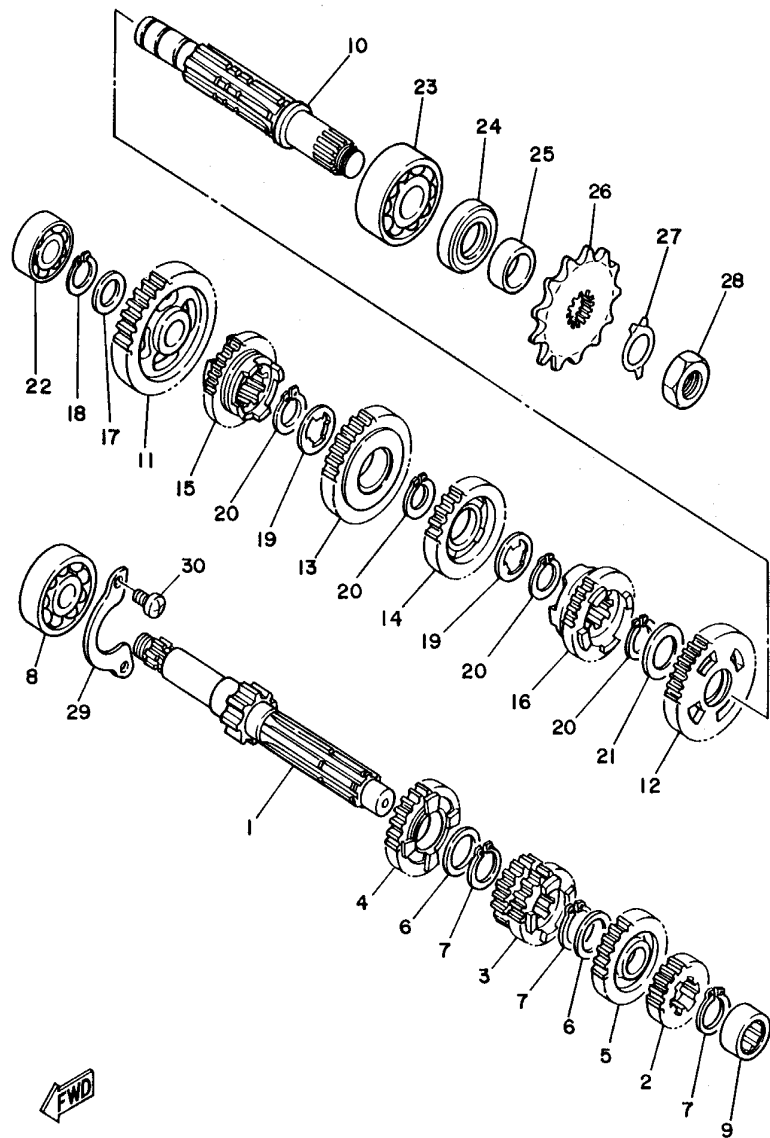

3XP1010-1130

FIG. 12 TRANSMISSION

REF. NO.	PART NO.	DESCRIPTION	Q'TY	REMARKS
1	4BF-17411-00	AXLE, MAIN (13T)	1	
2	3BN-17121-00	GEAR, 2ND PINION (16T)	1	
3	3BN-17131-01	GEAR, 3RD PINION	1	
4	3BN-17151-01	GEAR, 5TH PINION (23T)	1	
5	3BN-17161-02	GEAR, 6TH PINION	1	
6	90201-20266	WASHER, PLATE (1.0T)	2	
7	93410-20038	CIRCLIP	3	
8	93306-20469	BEARING (B62042RS)	1	
9	93311-31567	BEARING, CYLINDRICAL	1	
10	3BN-17421-00	AXLE, DRIVE	1	
11	4BF-17211-00	GEAR, 1ST WHEEL (32T)	1	
12	3BN-17221-00	GEAR, 2ND WHEEL (30T)	1	
13	3BN-17231-01	GEAR, 3RD WHEEL	1	
14	3XP-17241-00	GEAR, 4TH WHEEL	1	
15	3BN-17251-02	GEAR, 5TH WHEEL	1	
16	3XP-17261-00	GEAR, 6TH WHEEL	1	
17	90201-154E8	WASHER, PLATE	1	
18	99009-15400	CIRCLIP	1	
19	90209-18135	WASHER	2	
20	93410-22039	CIRCLIP	4	
21	90201-22555	WASHER, PLATE	1	
22	93306-20211	BEARING (6202SH2-C3)	1	
23	93306-30439	BEARING (B6304C3)	1	
24	93102-26042	OIL SEAL	1	
25	90387-205W8	COLLAR	1	
26	9383A-13031	SPROCKET, DRIVE 13T (2HG1746130)	1	
27	90215-20283	WASHER, LOCK	1	
28	90179-16613	NUT	1	

FIG. 12 TRANSMISSION

REF. NO.	PART NO.	DESCRIPTION	Q'TY	REMARKS
29	4BF-17471-00	PLATE, COVER	1	
30	98507-06012	SCREW, PAN HEAD	2	

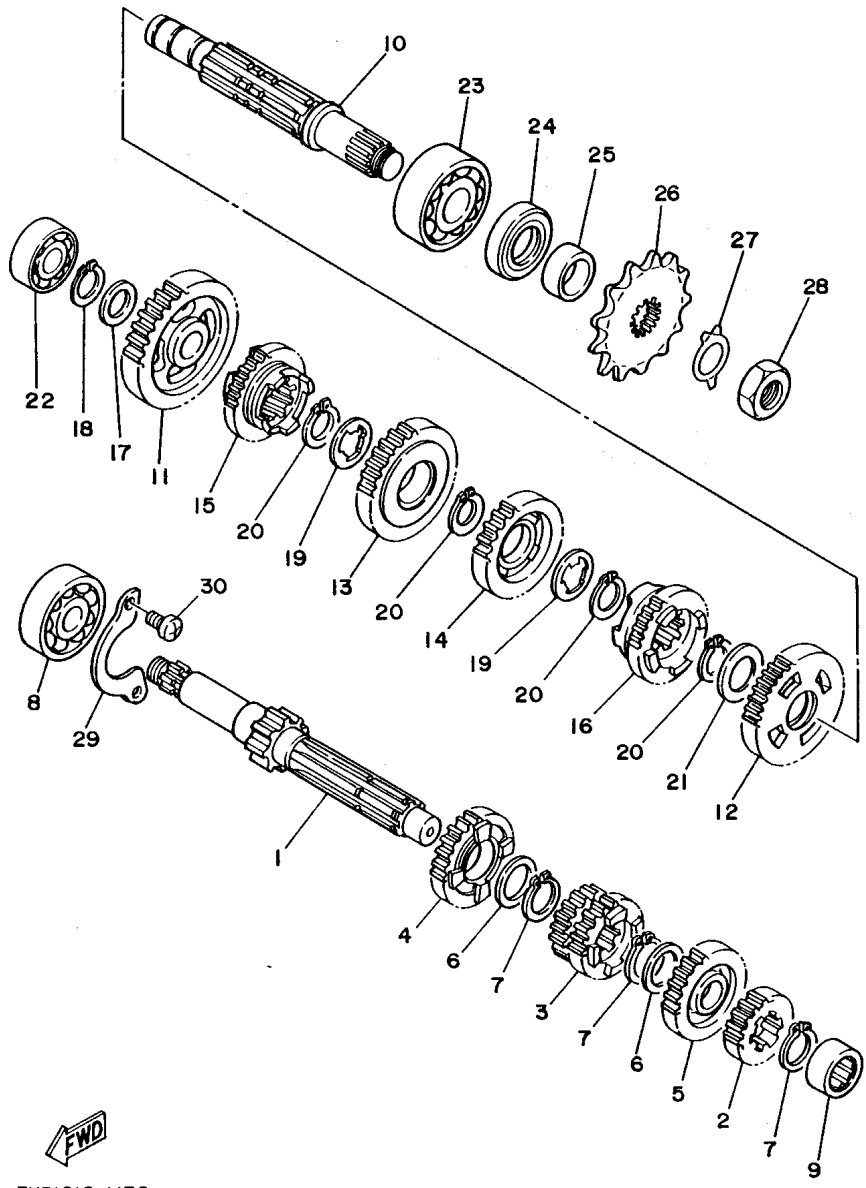

3XP1010-1130

C6

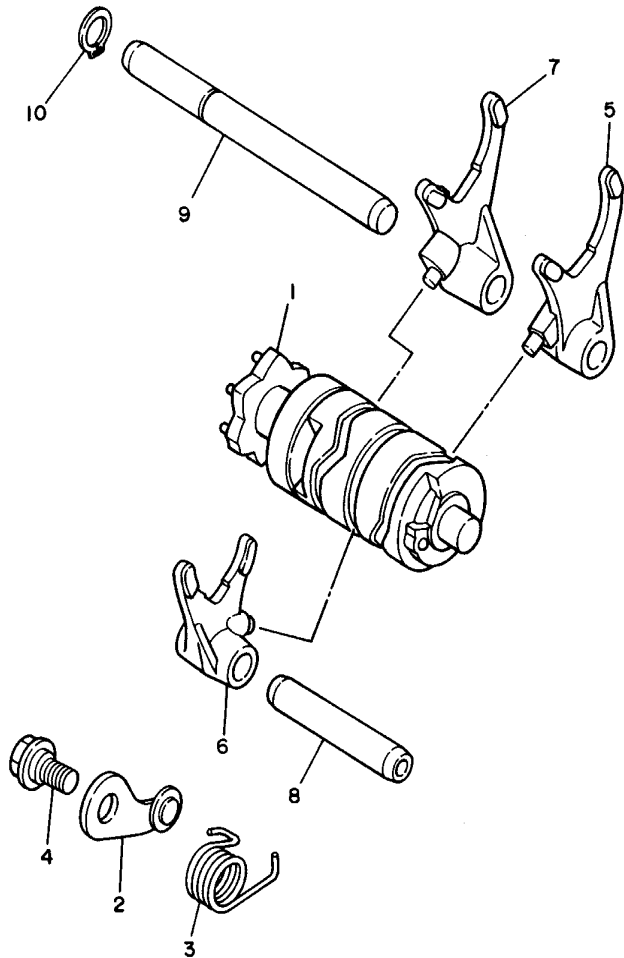

FIG. 13 SHIFT CAM. FORK

REF. NO.	PART NO.	DESCRIPTION	Q'TY	REMARKS
1	3XP-18540-00	SHIFT CAM ASSY	1	
2	3BN-18140-00	STOPPER LEVER ASSY	1	
3	90508-26561	SPRING, TORSION	1	
4	90109-063F7	BOLT	1	
5	55K-18511-01	FORK, SHIFT 1	1	
6	2RH-18512-00	FORK, SHIFT 2	1	
7	55K-18513-00	FORK, SHIFT 3	1	
8	55K-18531-00	BAR, SHIFT FORK GUIDE 1	1	
9	3BN-18535-00	BAR, SHIFT FORK GUIDE 2	1	
10	99009-10400	CIRCLIP	1	



38N300-8150

C7



FIG. 14 SHIFTER

REF. NO.	PART NO.	DESCRIPTION	Q'TY	REMARKS
1	10W-18101-03	SHIFT SHAFT ASSY	1	
2	93101-12060	OIL SEAL	1	
3	90508-32553	SPRING, TORSION	1	
4	99006-10600	CIRCLIP	1	
5	3XP-18110-00	SHIFT PEDAL ASSY	1	
6	1W6-18113-00	.COVER, SHIFT PEDAL	1	
7	97017-06020	BOLT	1	
8	3XP-18179-00	GUIDE	1	
9	2HH-22178-00	TENSIONER	1	
10	90202-12031	WASHER, PLATE	1	

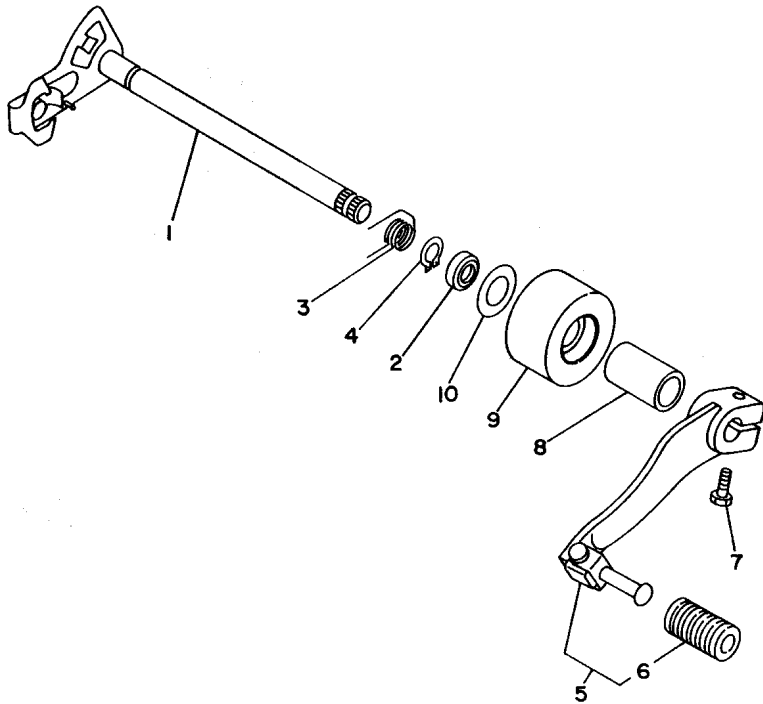

3XP3010-2150

**C8**

FIG. 15 FRAME

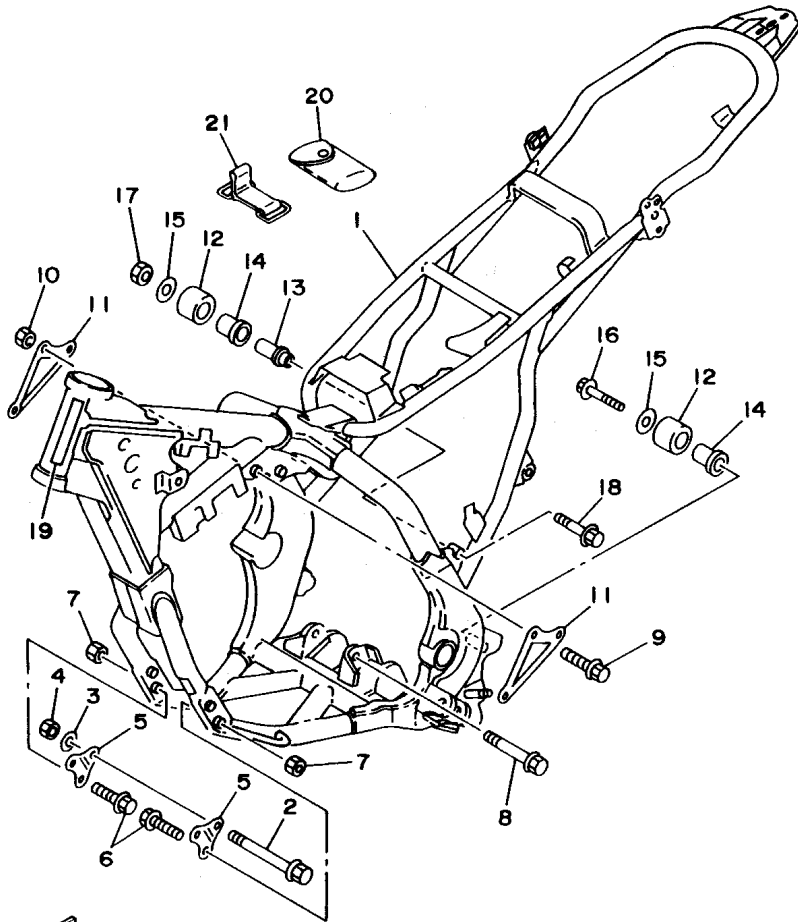

REF. NO.	PART NO.	DESCRIPTION	Q'TY	REMARKS
1	4BF-21110-10-G3	FRAME COMP.	1	FRENCH BLUE
2	90105-10645	BOLT, WASHER BASED	1	
3	90201-10M05	WASHER, PLATE	1	
4	90185-10060	NUT, SELF-LOCKING	1	
5	3XP-21415-00	BRACKET, FRONT UPPER 1	2	
6	90105-08663	BOLT, WASHER BASED	4	
7	95617-08200	NUT, SELF-LOCKING	4	
8	90105-08646	BOLT, WASHER BASED	1	
9	90105-08663	BOLT, WASHER BASED	3	
10	95617-08200	NUT, SELF-LOCKING	3	
11	3XP-21425-00	BRACKET, REAR UPPER 1	2	
12	30X-22178-00	TENSIONER	2	
13	2K7-2148A-00	SHAFT	1	
14	10V-22184-00	BUSH	2	
15	90201-08753	WASHER, PLATE	2	
16	95027-08050	BOLT, FLANGE	1	
17	95617-08100	NUT, U.	1	
18	95027-08012	BOLT, FLANGE	1	
19	1JK-21268-00	SEAL	1	
20	3XP-28100-00	TOOL KIT	1	
21	1KH-82131-00	BAND, BATTERY	1	

FWD

4BF2100-3150

C9

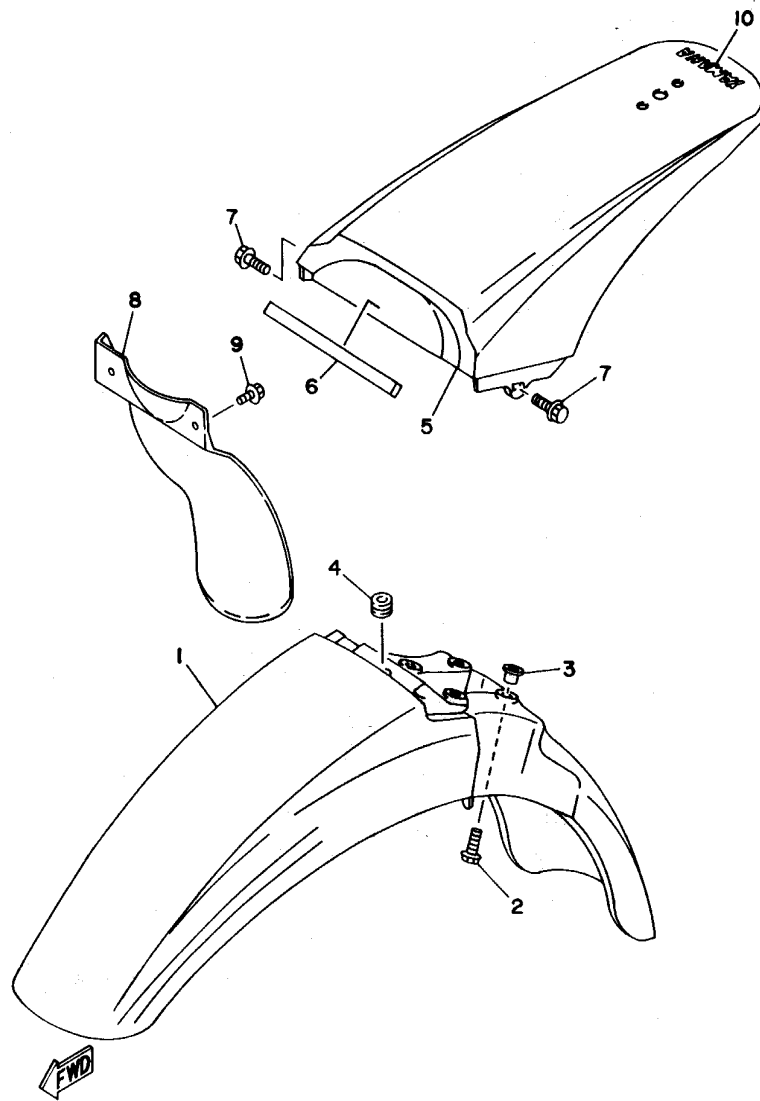

4BF3300-4160

FIG. 16 FENDER

REF. NO.	PART NO.	DESCRIPTION	Q'TY	REMARKS
1	3XP-21511-00	FENDER, FRONT	1	
2	90119-06097	BOLT, WITH WASHER	4	
3	90387-062V8	COLLAR	4	
4	90480-13398	GROMMET	1	
5	4BF-21611-00	FENDER, REAR	1	
6	3XP-21639-00	DAMPER 2	1	
7	90119-06228	BOLT, WITH WASHER	2	
8	39X-21642-00	GUARD, FLAP	1	
9	90119-06194	BOLT, WITH WASHER	2	
10	99247-00080	EMBLEM, YAMAHA	1	

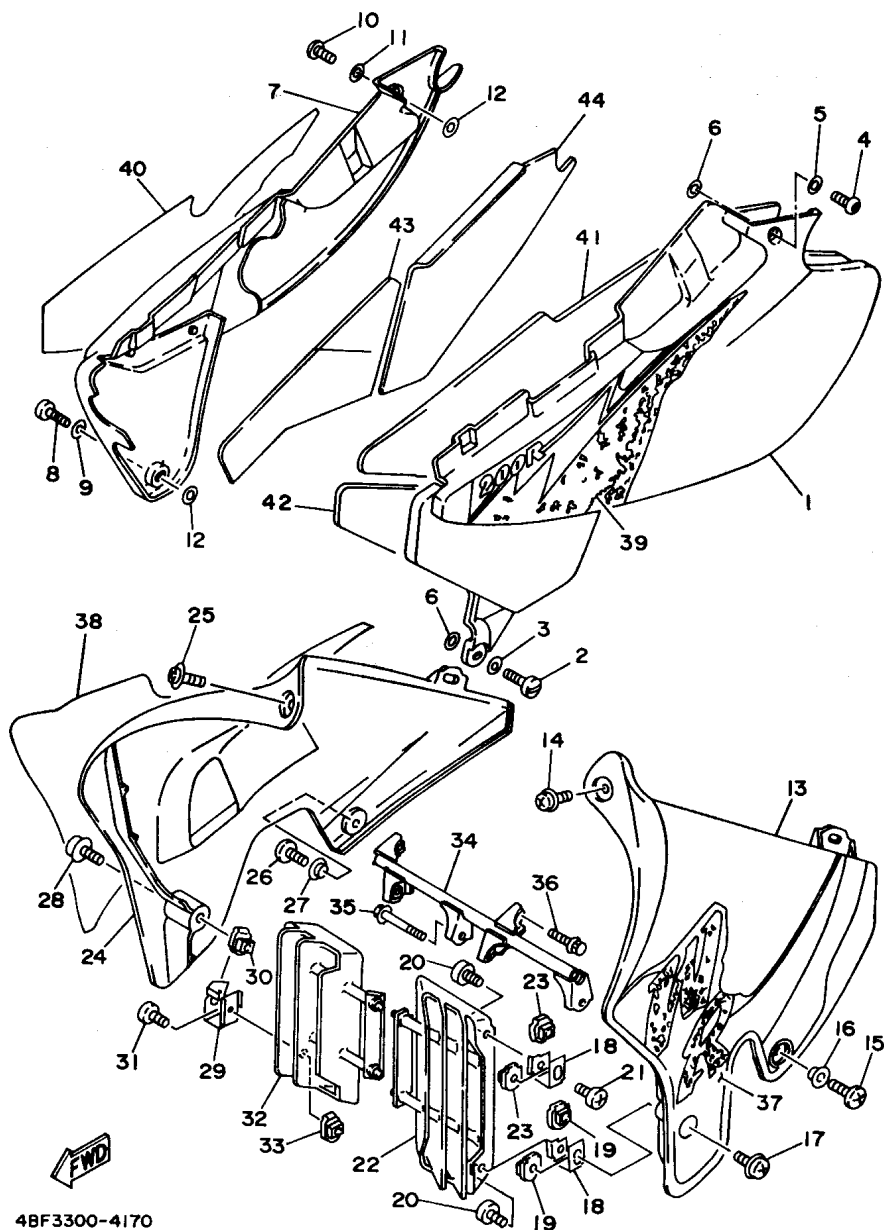

48F3300-4170

FIG. 17 SIDE COVER

REF. NO.	PART NO.	DESCRIPTION	Q'TY	REMARKS
1	3XP-21711-01	COVER, SIDE 1	1	PURPLISH WHITE SOLID 1
2	90149-06223	SCREW	1	
3	90201-062A8	WASHER, PLATE	1	
4	90149-06305	SCREW	1	
5	90201-06M08	WASHER, PLATE	1	
6	4U5-2176E-00	PLATE	2	
7	3XP-21721-01	COVER, SIDE 2	1	PURPLISH WHITE SOLID 1
8	90149-06223	SCREW	1	
9	90201-062A8	WASHER, PLATE	1	
10	90149-06305	SCREW	1	
11	90201-06M08	WASHER, PLATE	1	
12	4U5-2176E-00	PLATE	2	
13	3XP-21731-00	COVER, SIDE 3	1	PURPLISH WHITE SOLID 1
14	90159-06160	SCREW, WITH WASHER	1	
15	90154-05063	SCREW, BINDING	2	
16	90387-062M9	COLLAR	2	
17	90159-05183	SCREW, WITH WASHER	1	
18	3XP-2138K-00	BRACKET, 1	2	
19	22W-21791-00	NUT	2	
20	90159-05117	SCREW, WITH WASHER	2	
21	90159-05061	SCREW, WITH WASHER	1	
22	3XJ-2172A-00	PANEL 1	1	PURPLISH WHITE SOLID 1
23	22W-21791-00	NUT	2	
24	48F-21741-00	COVER, SIDE 4	1	PURPLISH WHITE SOLID 1
25	90159-06160	SCREW, WITH WASHER	1	
26	90154-05063	SCREW, BINDING	2	
27	90387-062M9	COLLAR	2	
28	90159-05183	SCREW, WITH WASHER	1	

C11

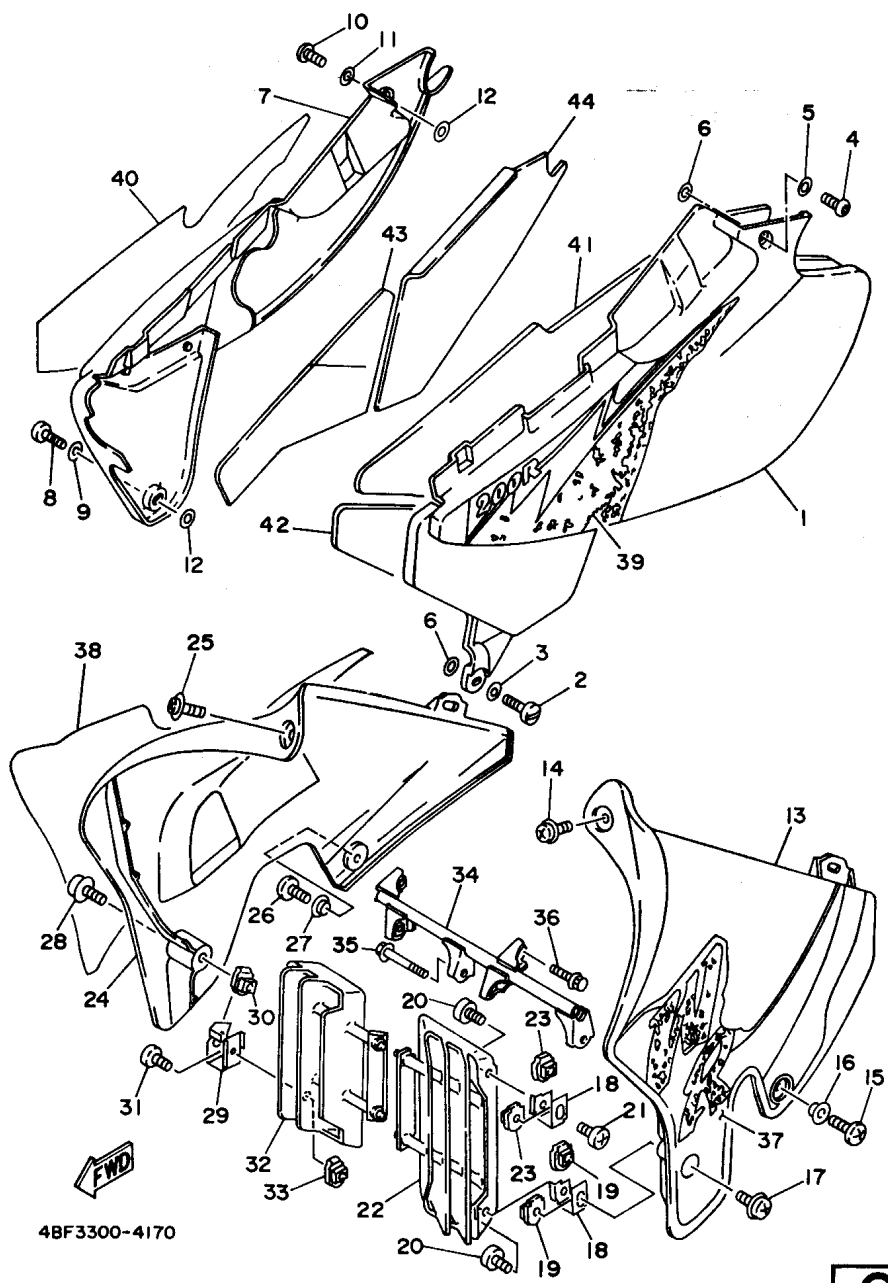

48F3300-4170

FIG. 17 SIDE COVER

REF. NO.	PART NO.	DESCRIPTION	Q'TY	REMARKS
29	48F-2138L-00	BRACKET 2	1	
30	22W-21791-00	NUT	1	
31	90157-05079	SCREW, PAN HEAD	1	
32	3XJ-2172F-00	PANEL 2	1	PURPLISH WHITE SOLID 1
33	22W-21791-00	NUT	2	
34	3XP-2174F-10	GUARD, RADIATOR	1	
35	95027-08045	BOLT, FLANGE	1	
36	95027-08012	BOLT, FLANGE	1	
37	48F-2174G-00	GRAPHIC 3	1	
38	48F-2174H-00	GRAPHIC 4	1	
39	48F-2173E-11	GRAPHIC 1	1	
40	48F-2173F-11	GRAPHIC 2	1	
41	3XP-21746-00	DAMPER	1	
42	3XP-21747-00	DAMPER	1	
43	3XP-2174A-00	INSULATOR, SIDE COVER	1	
44	3XP-2174T-00	INSULATOR, SIDE COVER 2	1	

C12

FIG. 18 OIL TANK

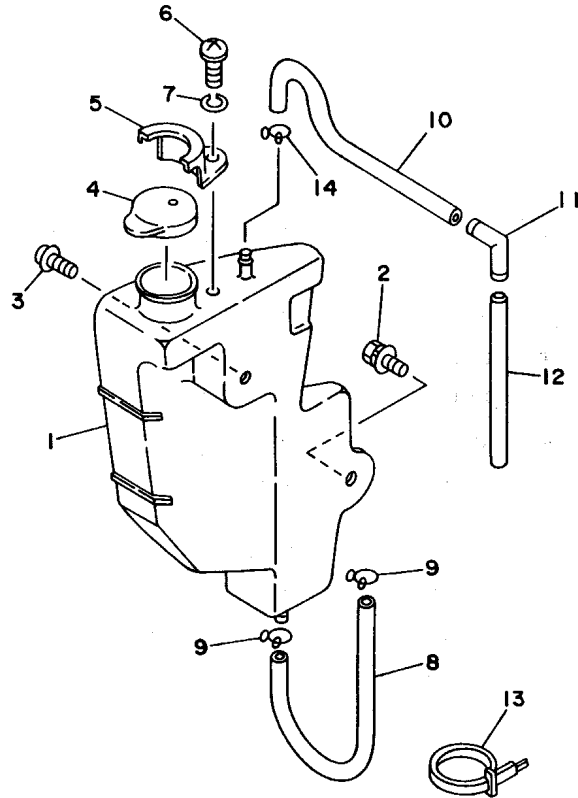

REF. NO.	PART NO.	DESCRIPTION	Q'TY	REMARKS
1	3XP-21871-00	TANK, RECOVERY	1	
2	90119-06205	BOLT, WITH WASHER	1	
3	90159-05183	SCREW, WITH WASHER	1	
4	1AA-21815-00	CAP	1	
5	3MA-2172N-00	BRACKET 4	1	
6	98507-06070	SCREW, PAN HEAD	1	
7	92907-06100	WASHER, SPRING	1	
8	3XP-25895-50	HOSE, RESERVOIR	1	
9	90467-08003	CLIP	2	
10	3XP-2589E-00	HOSE	1	
11	26H-21828-00	ELBOW	1	
12	90445-094F0	HOSE	1	
13	341-26397-01	BAND	1	
14	90467-08003	CLIP	1	



IBF1100-2180

C13

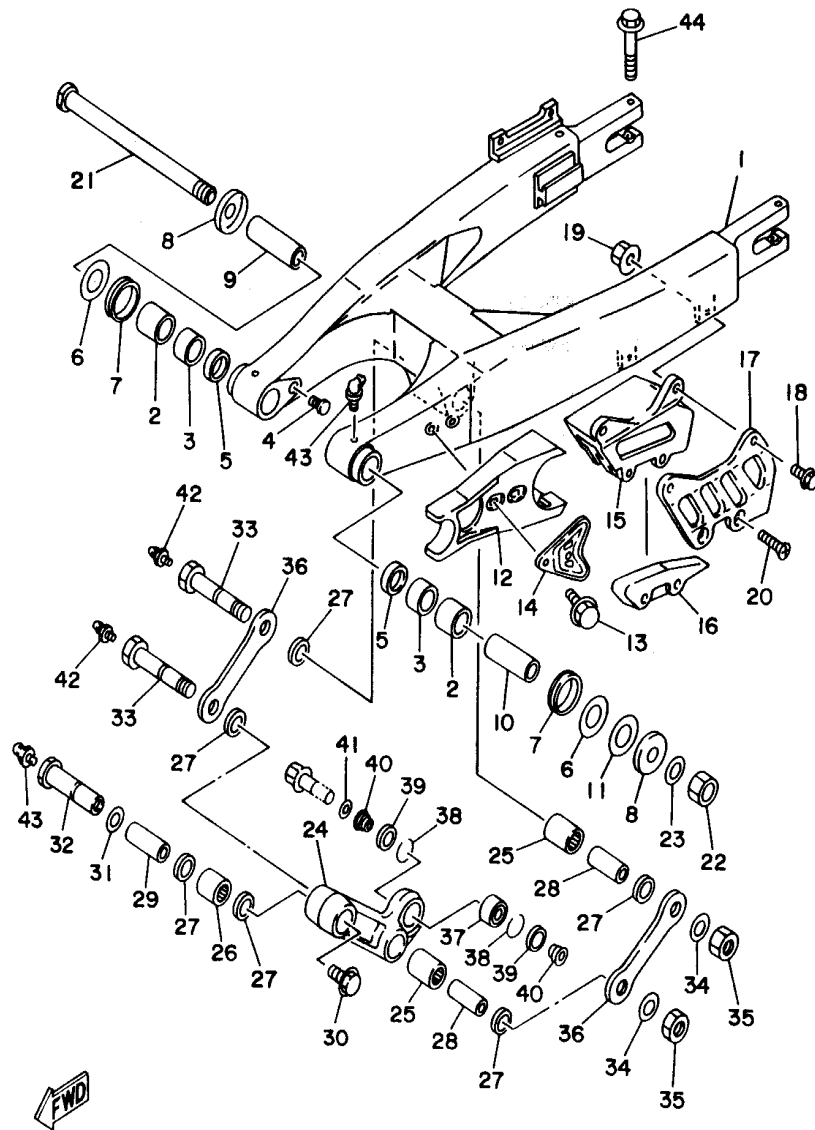

4BF3300-4190

FIG. 19 REAR ARM

REF. NO.	PART NO.	DESCRIPTION	Q'TY	REMARKS
1	4BF-22110-00-T9	REAR ARM COMP.	1	COMPETITION SILVER
2	93317-32231	BEARING, CYLINDRICAL	2	
3	90380-22111	BUSH, SOLID	2	
4	90338-10150	PLUG	2	
5	93106-22019	OIL SEAL (DC 22-28-8)	2	
6	90201-254H8	WASHER, PLATE	2	
7	93108-35004	OIL SEAL (35-41-8)	2	
8	30X-2219X-00	COVER	2	
9	90387-166X2	COLLAR	1	
10	90387-166X3	COLLAR	1	
11	90201-251F6	WASHER, PLATE (0.3T)	1	UN
12	3XP-22151-01	SEAL, GUARD	1	
13	95807-06014	BOLT, FLANGE	2	
14	3JD-22156-00	WASHER, PLATE	1	
15	3XP-22199-03	SUPPORT, CHAIN	1	
16	3JD-22147-00	PROTECTOR, CHAIN	1	
17	3JD-22128-00	COVER, THRUST 1	1	
18	90105-06601	BOLT, WASHER BASED	2	
19	95707-06500	NUT, FLANGE	2	
20	98707-06050	SCREW, FLAT HEAD	2	
21	1LX-22141-00	SHAFT, PIVOT	1	
22	90185-16127	NUT, SELF-LOCKING	1	
23	90201-164H4	WASHER, PLATE	1	
24	3XP-2217A-00	ARM, RELAY	1	
25	93315-22046	BEARING, CYLINDRICAL	2	
26	93315-22046	BEARING, CYLINDRICAL	1	
27	93109-20029	OIL SEAL	6	
28	90387-166X0	COLLAR	2	

FIG. 19 REAR ARM

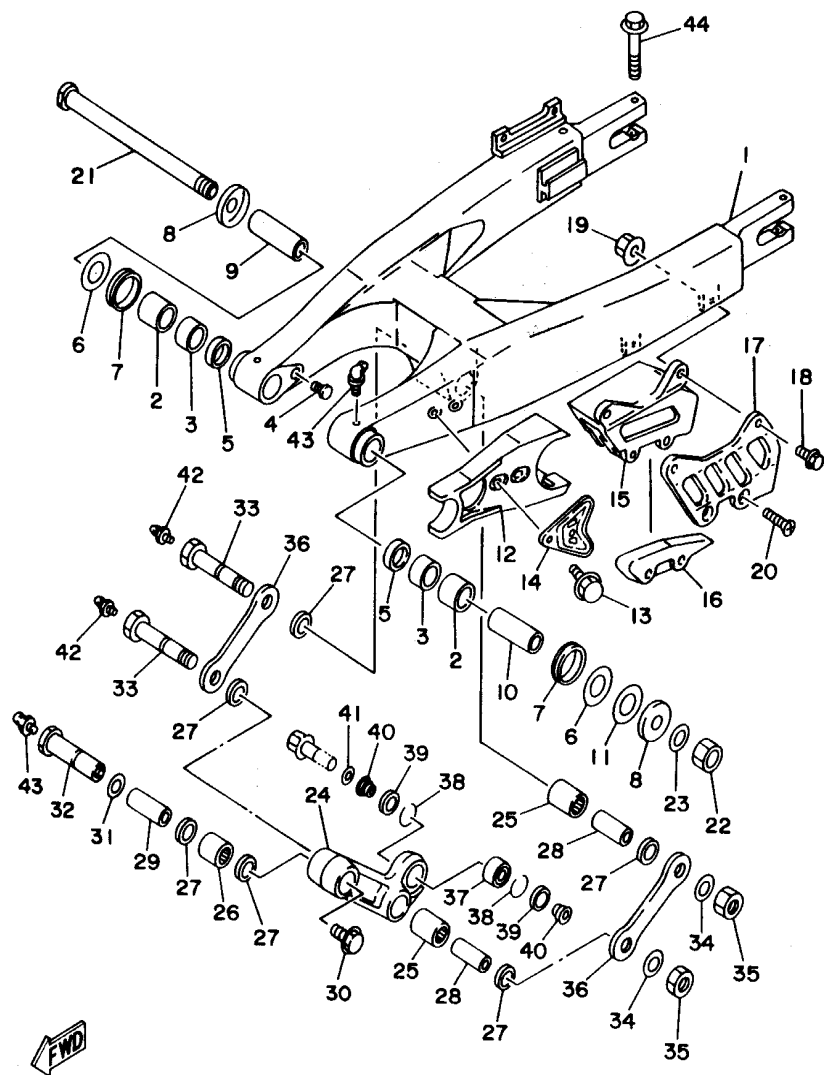

REF. NO.	PART NO.	DESCRIPTION	Q'TY	REMARKS
29	90387-166X1	COLLAR	1	
30	95817-10016	BOLT, FLANGE	1	
31	90201-106F2	WASHER, PLATE	1	
32	90179-10649	NUT	1	
33	90401-14147	BOLT, UNION	2	
34	90201-160F6	WASHER, PLATE	2	
35	90185-14070	NUT, SELF-LOCKING	2	
36	3XP-2217F-00	ROD, CONNECTING 1	2	
37	93399-99935	BEARING	1	
38	93440-30113	CIRCLIP	2	
39	3XJ-22475-00	SEAL, DUST	2	
40	90387-103X9	COLLAR	2	
41	90201-08759	WASHER, PLATE	1	
42	93700-06M03	NIPPLE, GREASE	2	
43	93700-06005	NIPPLE, GREASE	3	
44	95817-06045	BOLT, FLANGE	2	

48F3300-4190

C15



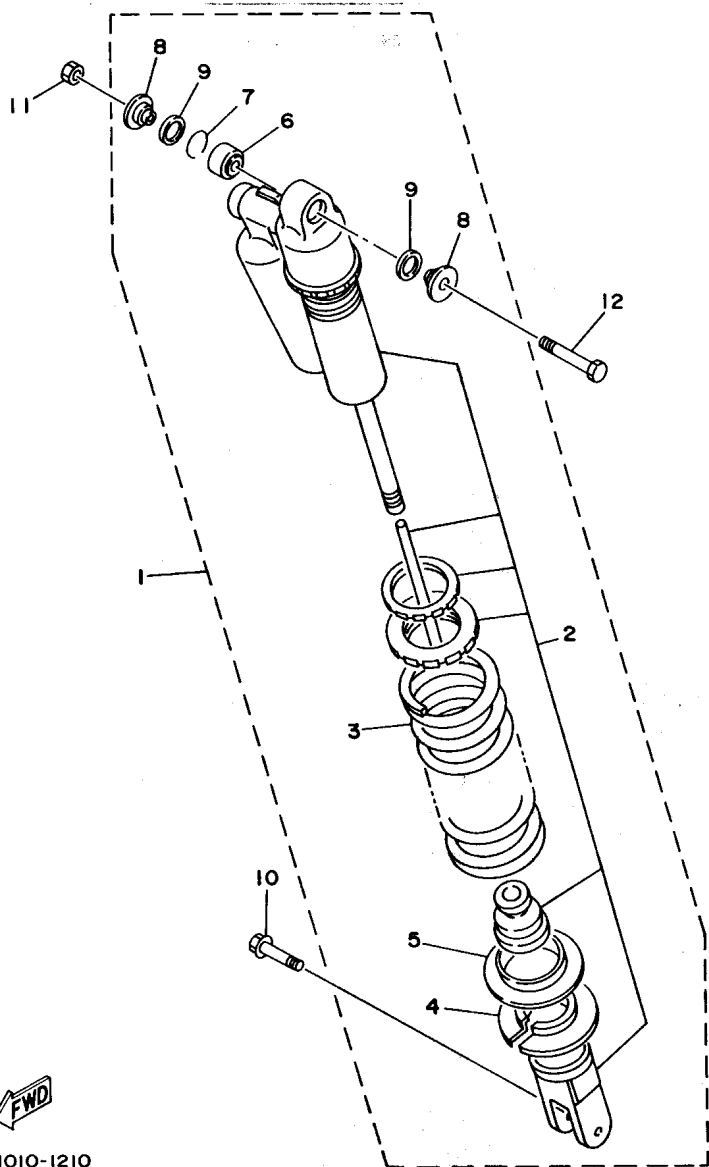

3XP1010-1210

FIG. 20 REAR SUSPENSION

REF. NO.	PART NO.	DESCRIPTION	Q'TY	REMARKS
1	4BF-22210-20-P1	SHOCK ABSORBER ASSY, REAR	1	LIGHT REDDISH YELLOW SOLID 1
2	4BF-22201-20	.DAMPER SUB ASSY	1	
3	4BF-22212-00-P1	.SPRING	1	LIGHT REDDISH YELLOW SOLID 1
4	3XP-22214-00	.GUIDE, SPRING 1	1	
5	3XP-22224-00	.GUIDE, SPRING 2	1	
6	93399-99936	.BEARING	1	
7	93440-30113	.CIRCLIP	1	
8	90387-100Y3	.COLLAR	2	
9	23X-22211-00	.COVER	2	
10	90105-10614	BOLT, WASHER BASED	1	
11	95617-10200	NUT, SELF-LOCKING	1	
12	3SP-22241-00	BOLT	1	

D2

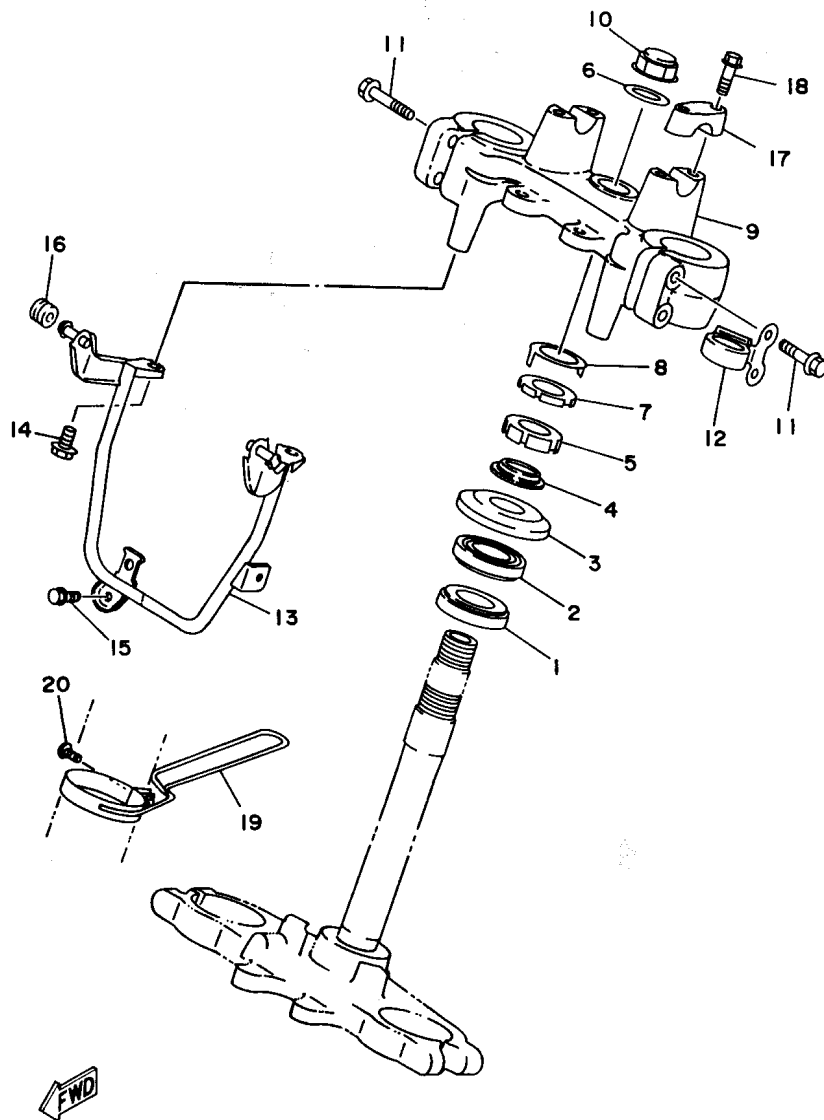

4BF1100-2210

FIG. 21 STEERING

REF. NO.	PART NO.	DESCRIPTION	Q'TY	REMARKS
1	93332-00067	BEARING	1	
2	93332-00068	BEARING	1	
3	3XP-23416-00	COVER, BALL RACE 2	1	
4	3XP-23462-00	SEAL, STEERING	1	
5	90179-25614	NUT	1	
6	90202-26142	WASHER, PLATE	1	
7	90179-25615	NUT	1	
8	26H-23418-01	WASHER, SPECIAL	1	
9	4BF-23435-01-35	CROWN, HANDLE	1	SILVER
10	90176-22050	NUT, CROWN	1	
11	95027-08040	BOLT, FLANGE	4	
12	3XP-23389-00	GUIDE, CABLE	1	
13	4BF-23174-01	STAY, HEADLIGHT	1	
14	95027-06012	BOLT, FLANGE	2	
15	95817-06012	BOLT, FLANGE	1	
16	90480-12053	GROMMET	2	
17	1E6-23441-10-35	HOLDER, HANDLE UPPER	2	SILVER
18	95027-08035	BOLT, FLANGE	4	
19	3XP-23318-00	HOLDER, CABLE 1	1	
20	98507-05012	SCREW, PAN HEAD	1	

D3

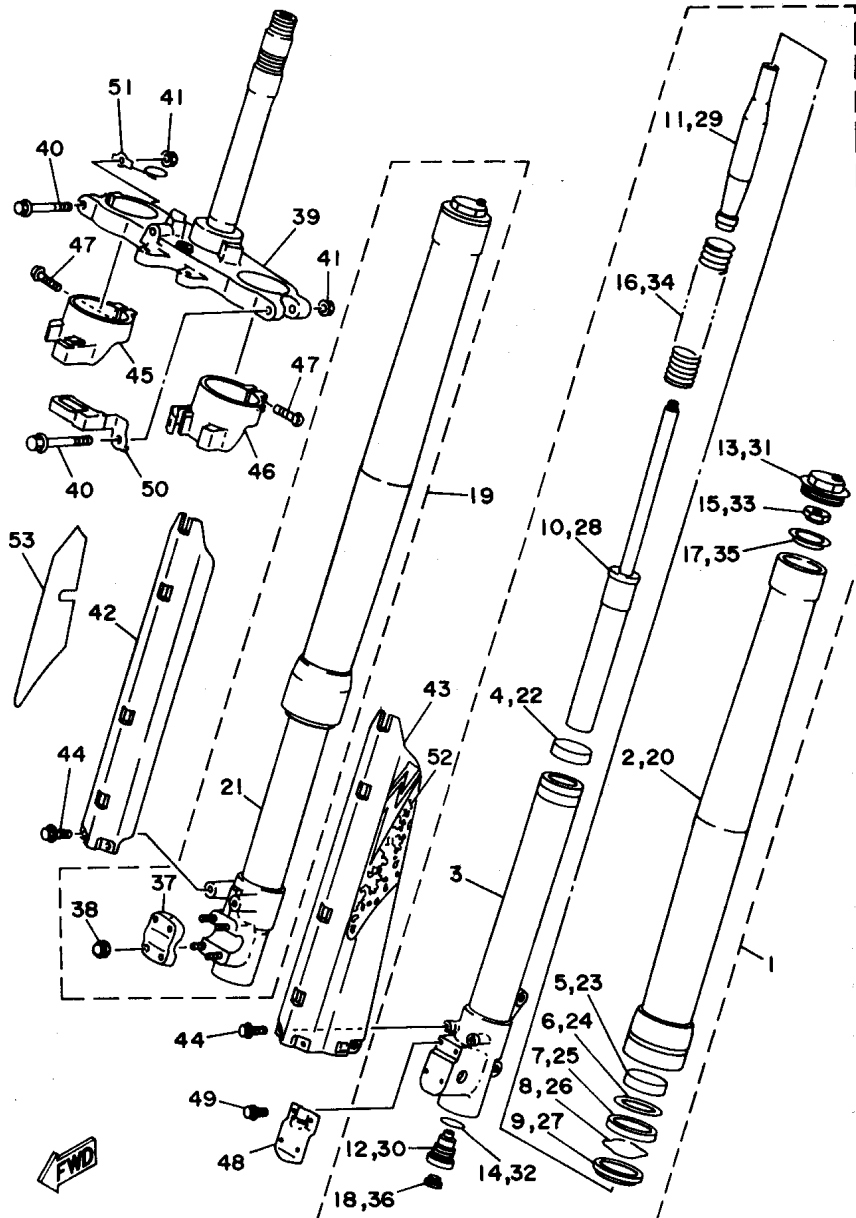

4BF3300-4220

FIG. 22 FRONT FORK

REF. NO.	PART NO.	DESCRIPTION	Q'TY	REMARKS
1	4BF-23102-10	FRONT FORK ASSY (L.H)	1	
2	3XP-23136-30	.TUBE, OUTER (RIGHT)	1	
3	3XP-23120-00	.INNER TUBE COMP.2	1	
4	3JD-23171-L0	.METAL, SLIDE	1	
5	3JD-23125-L0	.METAL, SLIDE 1	1	
6	36Y-23146-10	.WASHER, OIL SEAL	1	
7	3SP-23145-L0	.OIL SEAL	1	
8	26H-23156-00	.CLIP, OIL SEAL	1	
9	3SP-23144-L0	.SEAL, DUST	1	
10	3XP-23170-00	.CYLINDER COMP., FRONT FORK	1	
11	3XP-23142-00	.SEAT, SPRING UPPER	1	
12	4BF-2316A-00	.VALVE COMP.	1	
13	3XP-23111-00	.BOLT, CAP	1	
14	2HH-23158-L0	.GASKET	1	
15	3XP-23778-00	.NUT	1	
16	4BF-23141-00	.SPRING, FRONT FORK	1	
17	3SP-23143-L0	.SEAT, SPRING LOWER	1	
18	55Y-2312G-M0	.PLUG	1	
19	4BF-23103-10	FRONT FORK ASSY (R.H)	1	
20	3XP-23136-30	.TUBE, OUTER (RIGHT)	1	
21	3XP-23110-00	.INNER TUBE COMP.1	1	
22	3JD-23171-L0	.METAL, SLIDE	1	
23	3JD-23125-L0	.METAL, SLIDE 1	1	
24	36Y-23146-10	.WASHER, OIL SEAL	1	
25	3SP-23145-L0	.OIL SEAL	1	
26	26H-23156-00	.CLIP, OIL SEAL	1	
27	3SP-23144-L0	.SEAL, DUST	1	
28	3XP-23170-00	.CYLINDER COMP., FRONT FORK	1	

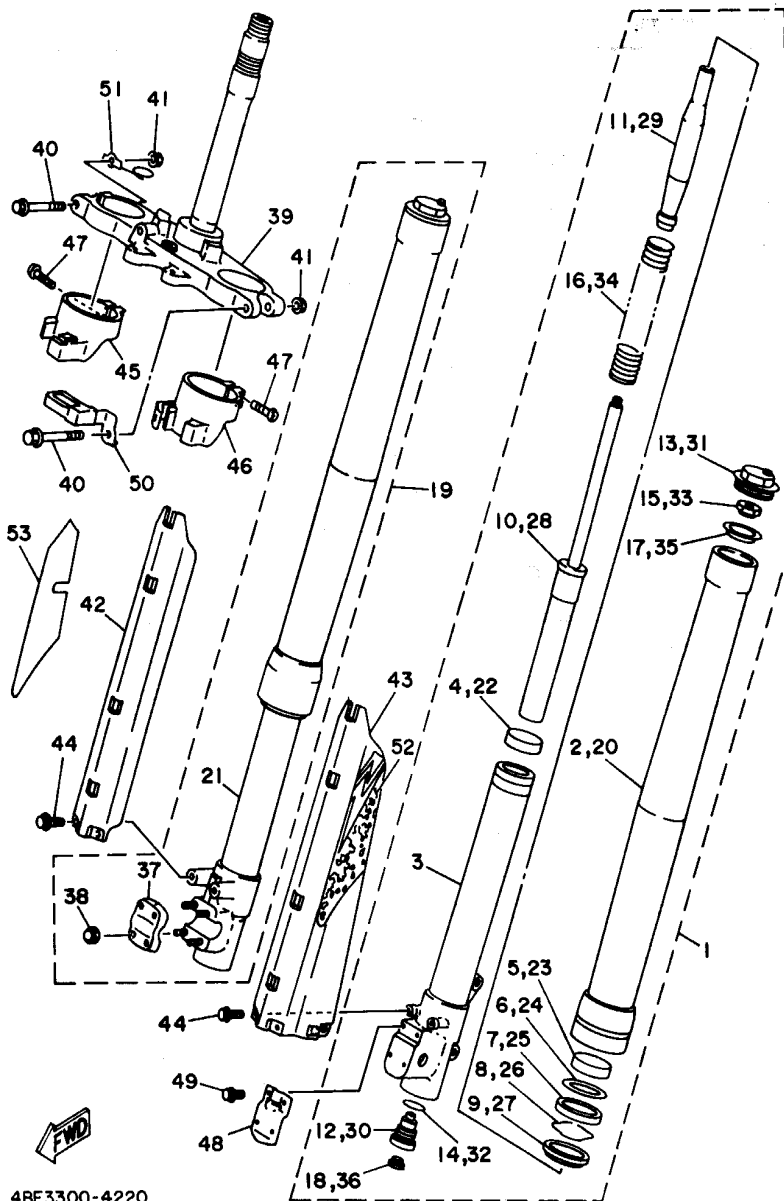

4BF3300-4220

FIG. 22 FRONT FORK

REF. NO.	PART NO.	DESCRIPTION	Q'TY	REMARKS
29	3XP-23142-00	.SEAT, SPRING UPPER	1	
30	4BF-2316A-00	.VALVE COMP.	1	
31	3XP-23111-00	.BOLT, CAP	1	
32	2HH-23158-LO	.GASKET	1	
33	3XP-23778-00	.NUT	1	
34	4BF-23141-00	.SPRING, FRONT FORK	1	
35	3SP-23143-LO	.SEAT, SPRING LOWER	1	
36	55Y-2312G-MO	.PLUG	1	
37	3XJ-23167-LO	.HOLDER, AXLE	1	
38	2KF-23127-01	.NUT	4	
39	3XP-23340-00	UNDER BRACKET COMP.	1	
40	3XP-23346-00	BOLT 1	2	
41	95701-10500	NUT, FLANGE	2	
42	3XP-2314J-LO	PROTECTOR COMP., 2	1	
43	3SP-2314H-LO	PROTECTOR COMP., 1	1	
44	3SP-23356-LO	BOLT 2	6	
45	3SP-2314G-LO	PROTECTOR GUIDE COMP., 2	1	
46	3SP-2314F-LO	PROTECTOR GUIDE COMP., 1	1	
47	4V4-23194-LO	SCREW, BOOT BAND	4	
48	4EW-2314E-LO	COVER, HOSE	1	
49	3SP-23346-LO	BOLT 1	4	
50	3XP-23318-10	HOLDER, CABLE 1	1	
51	3XP-23389-10	GUIDE, CABLE	1	
52	4JW-2313B-00	EMBLEM 1	1	
53	4BF-2313C-01	EMBLEM 2	1	

D5

FIG. 23 FUEL TANK

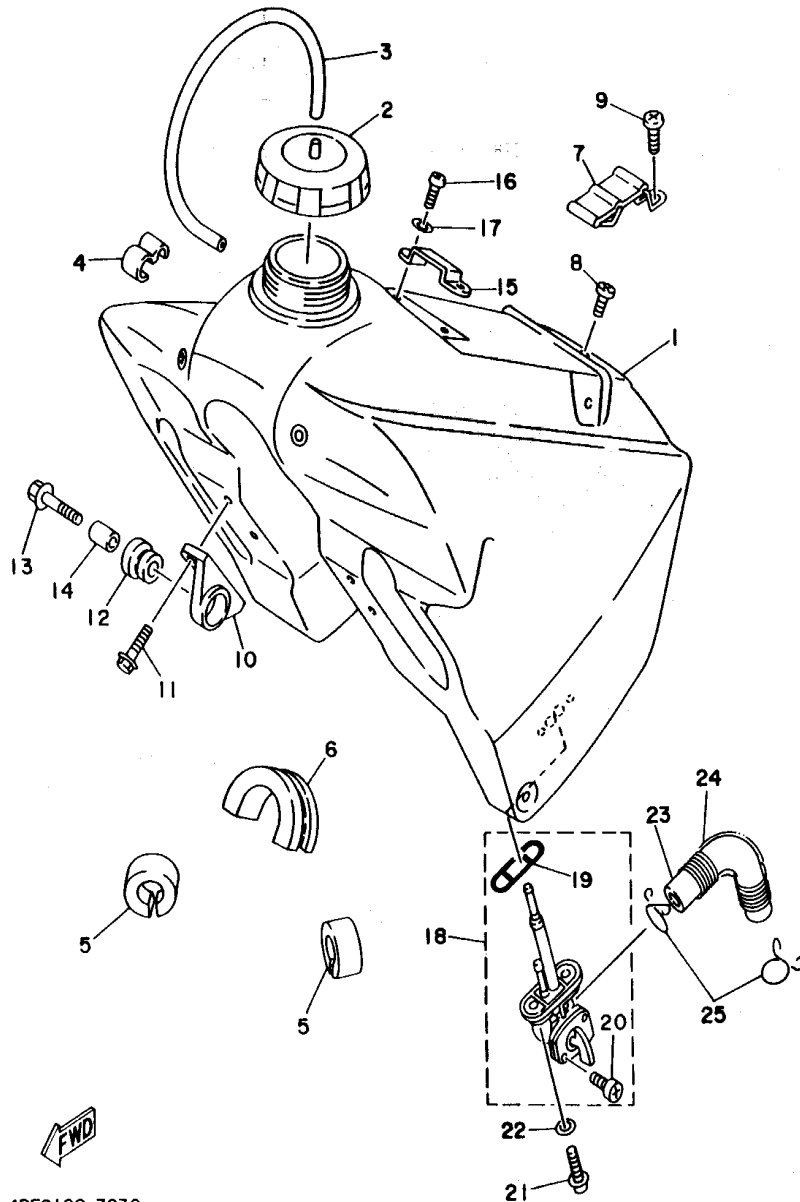

REF. NO.	PART NO.	DESCRIPTION	Q'TY	REMARKS
1	4BF-24110-00	FUEL TANK COMP.	1	
2	1UY-24610-00	CAP ASSY	1	
3	90445-09304	HOSE	1	
4	90468-15064	CLIP	1	
5	3XJ-21717-00	DAMPER, SIDE COVER	2	
6	1LX-24181-00	DAMPER, LOCATING 1	1	
7	4BF-24173-00	BAND, TANK FITTING 1	1	
8	98980-06020	SCREW, BIND	1	
9	90149-06165	SCREW	1	
10	24X-24144-00	HOLDER, DAMPER	2	
11	95027-06014	BOLT, FLANGE	4	
12	90480-18354	GROMMET	2	
13	90119-06214	BOLT, WITH WASHER	2	
14	90387-06387	COLLAR	2	
15	5X6-2412F-00	BRACKET, SEAT	1	
16	98507-06012	SCREW, PAN HEAD	2	
17	92907-06100	WASHER	2	
18	3XP-24500-00	FUEL COCK ASSY 1	1	
19	4X8-24512-00	.O-RING	1	
20	98580-03008	.SCREW, PAN HEAD	2	
21	90149-06011	SCREW	2	
22	90202-05187	WASHER, PLATE	2	
23	3XP-24311-10	PIPE, FUEL 1	1	
24	90501-080J1	SPRING, COMPRESSION	1	
25	90467-10008	CLIP	2	

FIG. 24 SEAT

REF. NO.	PART NO.	DESCRIPTION	Q'TY	REMARKS
1	4BF-24770-10	SEMI-DOUBLE SEAT ASSY	1	
2	4BF-24731-10	.COVER, SEAT	1	
3	509-24724-00	.DAMPER, SEAT	2	
4	90119-06043	BOLT, WITH WASHER	2	

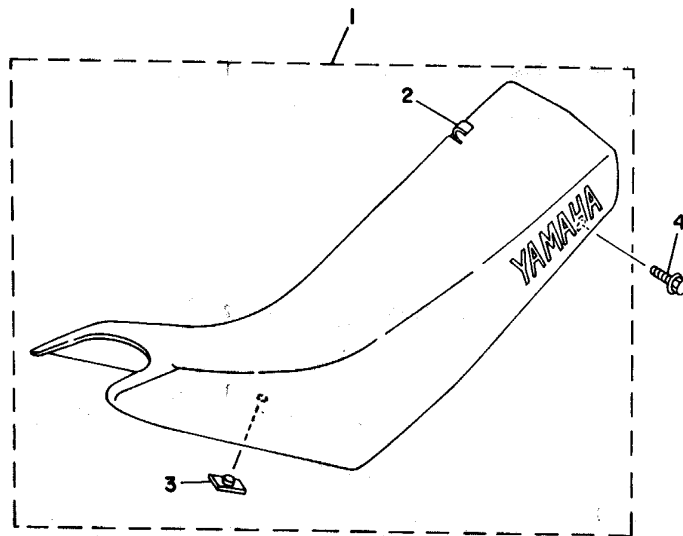

4BF1100-2240

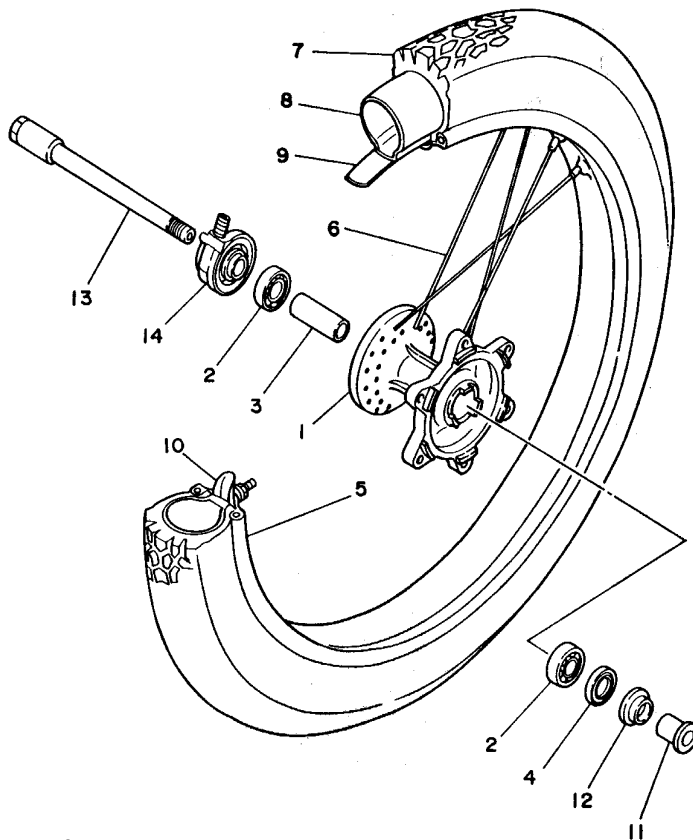

FIG. 25 FRONT WHEEL

REF. NO.	PART NO.	DESCRIPTION	Q'TY	REMARKS
1	3XP-25111-00-35	HUB, FRONT	1	SILVER
2	93306-20209	BEARING (B6202)	2	
3	90560-15290	SPACER	1	
4	93102-20281	OIL SEAL (SD 20-35-5)	1	
5	94416-21430	RIM (1.60-21)	1	
6	55U-25104-00	SPOKE SET, FRONT	1	
7	94108-217X2	TIRE (80/100-21 K490)	1	DUNLOP
8	94227-21123	TUBE (2.75-21)	1	BRIDGESTONE
9	94307-21145	BAND, RIM (70-80/100-21)	1	DUNLOP
10	5X2-25394-00	SPACER, BEAD	1	
11	90387-15600	COLLAR	1	
12	322-25118-00	COVER, HUB DUST	1	
13	55U-25181-01	AXLE, WHEEL	1	
14	3XP-25190-00	GEAR UNIT ASSY	1	



4BF1100-2250

D8

FIG. 26 FRONT BRAKE CALIPER

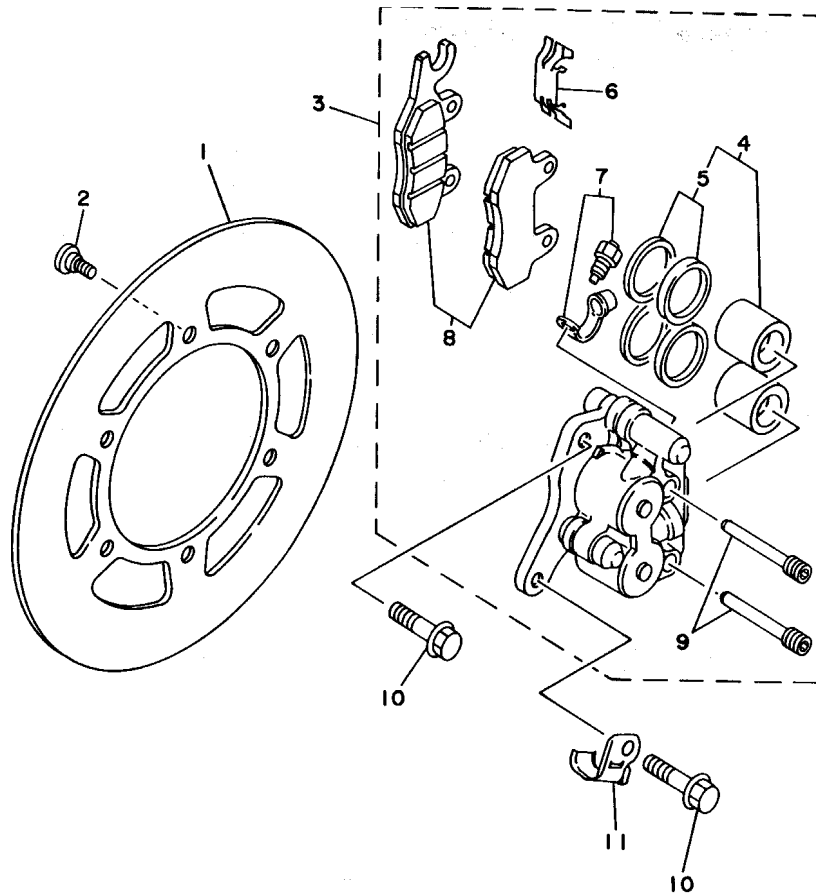

REF. NO.	PART NO.	DESCRIPTION	Q'TY	REMARKS
1	3XP-2582T-00	DISC, BRAKE	1	
2	90109-065F3	BOLT	6	
3	3XP-2580T-01	CALIPER ASSY (LEFT)	1	
4	3JD-W0057-00	.PISTON ASSY, CALIPER	1	
5	3JD-W0047-00	..CALIPER SEAL KIT	1	
6	3SP-25919-01	.SUPPORT, PAD	1	
7	36Y-W0048-00	.BREED SCREW KIT	1	
8	3XP-W0045-00	.BRAKE PAD KIT	1	
9	3GD-25933-00	.PIN, PAD	2	
10	90105-08659	BOLT, WASHER BASED	2	
11	3XP-25875-00	HOLDER, BRAKE HOSE 1	1	



3XP1010-1270

D9



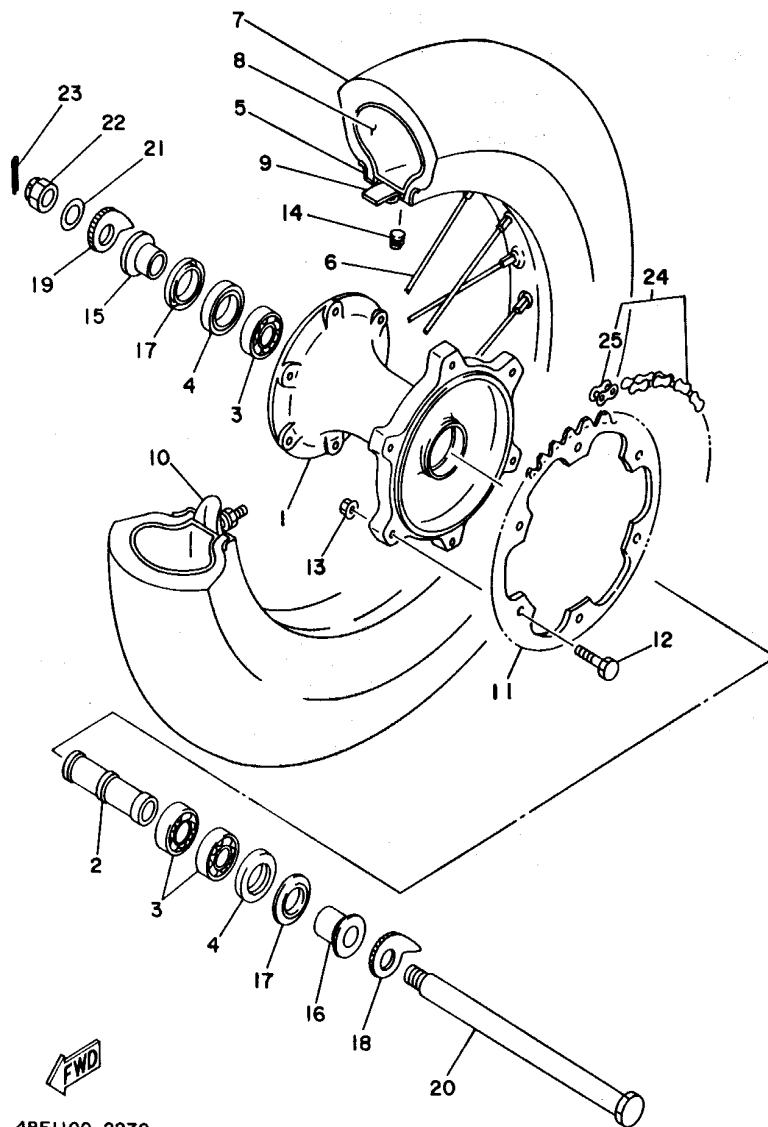

48F1100-2270

FIG. 27 REAR WHEEL

REF. NO.	PART NO.	DESCRIPTION	Q'TY	REMARKS
1	3XP-25311-00-35	HUB, REAR	1	SILVER
2	90560-20278	SPACER	1	
3	93306-00438	BEARING	3	
4	93106-28023	OIL SEAL	2	
5	94418-18452	RIM (1.85-18)	1	
6	2VN-25304-00	SPOKE SET, REAR	1	
7	94110-180Y2	TIRE (100/100-18 59M K695)	1	DUNLOP
8	94211-18176	TUBE (100-120/80-100-18)	1	DUNLOP
9	94309-18146	BAND, RIM	1	DUNLOP
10	2X3-25394-00	SPACER, BEAD	1	
11	2YY-25452-00	SPROCKET, DRIVEN (52T)	1	
12	90109-08618	BOLT	6	
13	90185-08146	NUT, SELF-LOCKING	6	
14	90480-10068	GROMMET	1	
15	90387-202U8	COLLAR	1	
16	90387-206X8	COLLAR	1	
17	3GB-25367-00	COVER, HUB DUST	2	
18	3BN-25388-00	PULLER, CHAIN 1	1	
19	3BN-25389-00	PULLER, CHAIN 2	1	
20	3XP-25381-00	AXLE, WHEEL	1	
21	90201-204M9	WASHER, PLATE	1	
22	90171-18053	NUT, CASTLE	1	
23	91401-30030	PIN, COTTER	1	
24	94581-47116	CHAIN	1	
25	94681-47011	JOINT, CHAIN	1	

FIG. 28 REAR BRAKE CALIPER

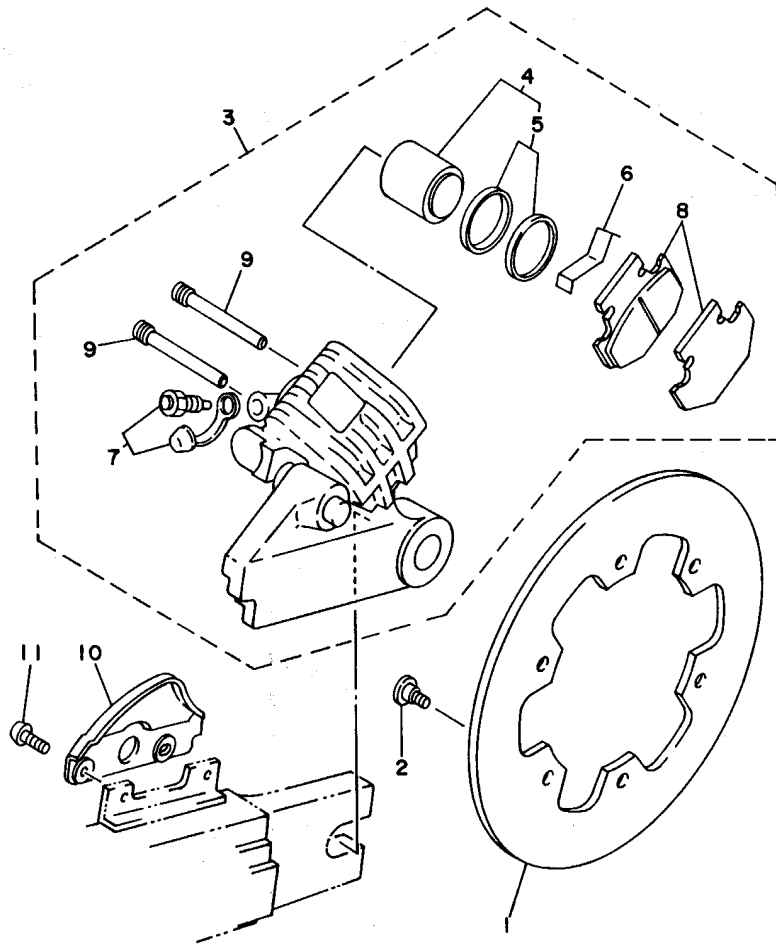

REF. NO.	PART NO.	DESCRIPTION	Q'TY	REMARKS
1	3XP-2582W-00	DISC, REAR BRAKE 2	1	
2	90109-065F3	BOLT	6	
3	3XP-2580W-00	CALIPER ASSY, REAR 2	1	
4	3SP-W0057-50	.PISTON ASSY, CALIPER	1	
5	3JD-W0047-50	..CALIPER SEAL KIT	1	
6	3SP-25919-51	.SUPPORT, PAD	1	
7	36Y-W0048-00	.BREED SCREW KIT	1	
8	3XP-W0046-00	.BRAKE PAD KIT, 2	1	
9	3SP-25924-51	.PIN, PAD	2	
10	3JD-27491-00	PROTECTOR	1	
11	92014-06012	BOLT, BUTTON HEAD	2	



3XP1010-1290

**D11**

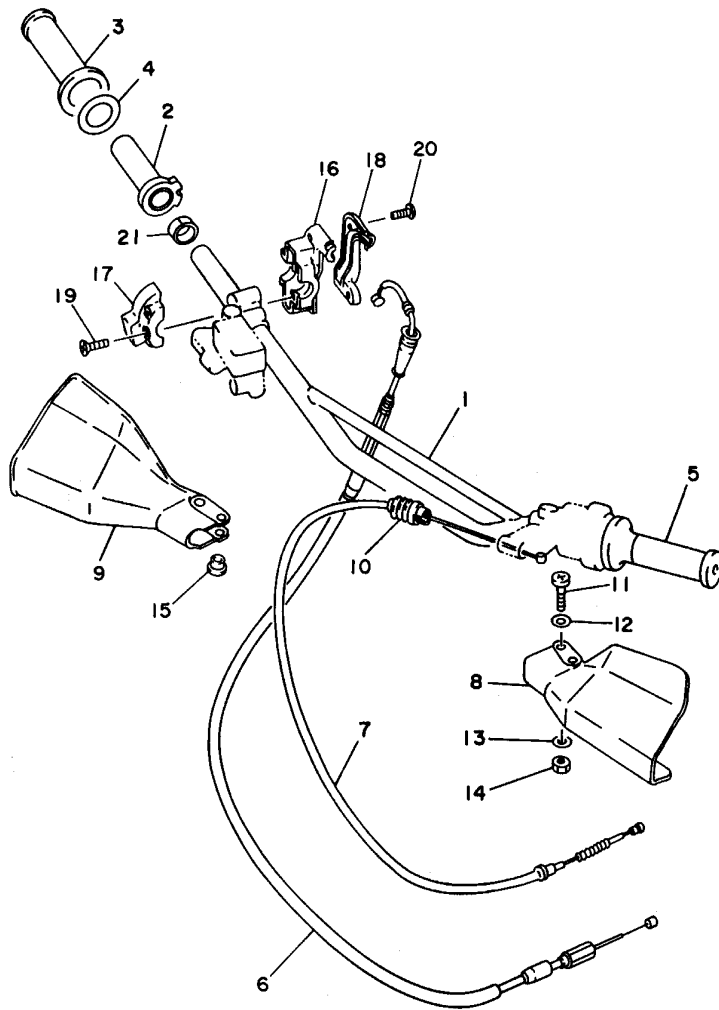

FIG. 29 STEERING HANDLE. CABLE

REF. NO.	PART NO.	DESCRIPTION	Q'TY	REMARKS
1	4EW-26111-00	HANDLEBAR	1	
2	322-26243-00	TUBE, THROTTLE GUIDE	1	
3	1LX-26242-01	GRIP (RIGHT)	1	
4	1M1-26249-01	RING, LEAF	1	
5	1LX-26241-01	GRIP (LEFT)	1	
6	4BF-26311-00	CABLE, THROTTLE 1	1	
7	3XP-26335-00	CABLE, CLUTCH	1	
8	3BN-26141-20	GUARD, BRUSH 1	1	PURPLISH WHITE SOLID 1
9	3BN-26142-20	GUARD, BRUSH 2	1	PURPLISH WHITE SOLID 1
10	1E6-26342-00	BOOT, CABLE	1	
11	98507-06035	SCREW, PAN HEAD	1	
12	92907-06600	WASHER, PLATE	1	
13	92907-06600	WASHER, PLATE	1	
14	95607-06100	NUT, U	1	
15	90387-06500	COLLAR	1	
16	5X2-26281-00	CAP, GRIP UPPER	1	
17	322-26282-00	CAP, GRIP LOWER	1	
18	5X2-2628H-01	CAP, WIRE	1	
19	98707-04012	SCREW, FLAT HEAD	2	
20	98507-05016	SCREW, PAN HEAD	2	
21	90387-22660	COLLAR	1	



4BF3300-4290

D12

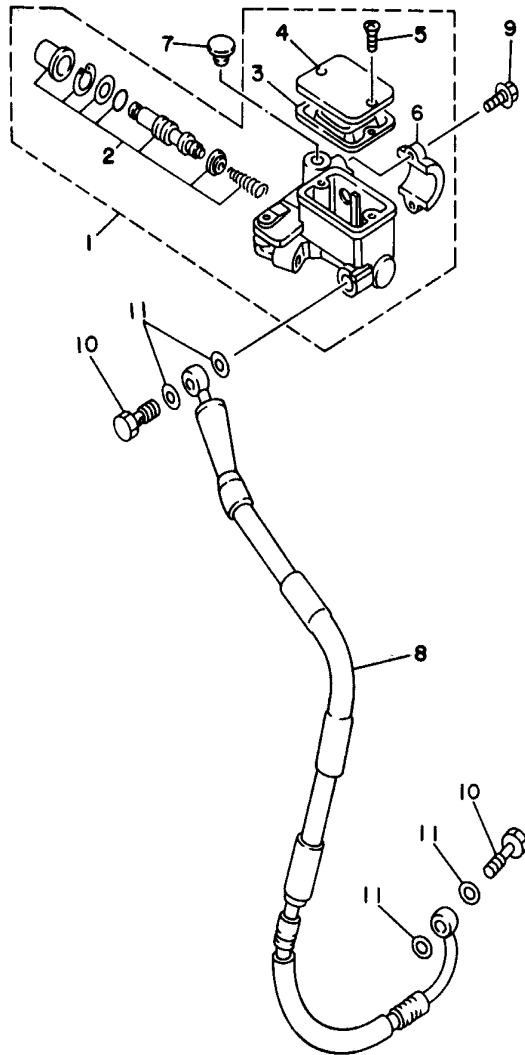

FIG. 30 FRONT MASTER CYLINDER

REF. NO.	PART NO.	DESCRIPTION	Q'TY	REMARKS
1	3XP-2583T-00	MASTER CYLINDER ASSY	1	
2	3XP-W0041-00	.CYLINDER KIT, MASTER	1	
3	55U-25854-00	.DIAPHRAGM, RESERVOIR	1	
4	2KF-25852-01	.CAP, RESERVOIR	1	
5	98707-04012	.SCREW, FLAT HEAD	2	
6	56A-25867-00	.BRACKET, MASTER CYLINDER	1	
7	90338-09012	PLUG	1	
8	4BF-25872-01	HOSE, BRAKE 1	1	
9	95807-06022	BOLT, FLANGE	2	
10	90401-10159	BOLT, UNION	2	
11	90201-10118	WASHER, PLATE	4	



48F4300-5300

D13

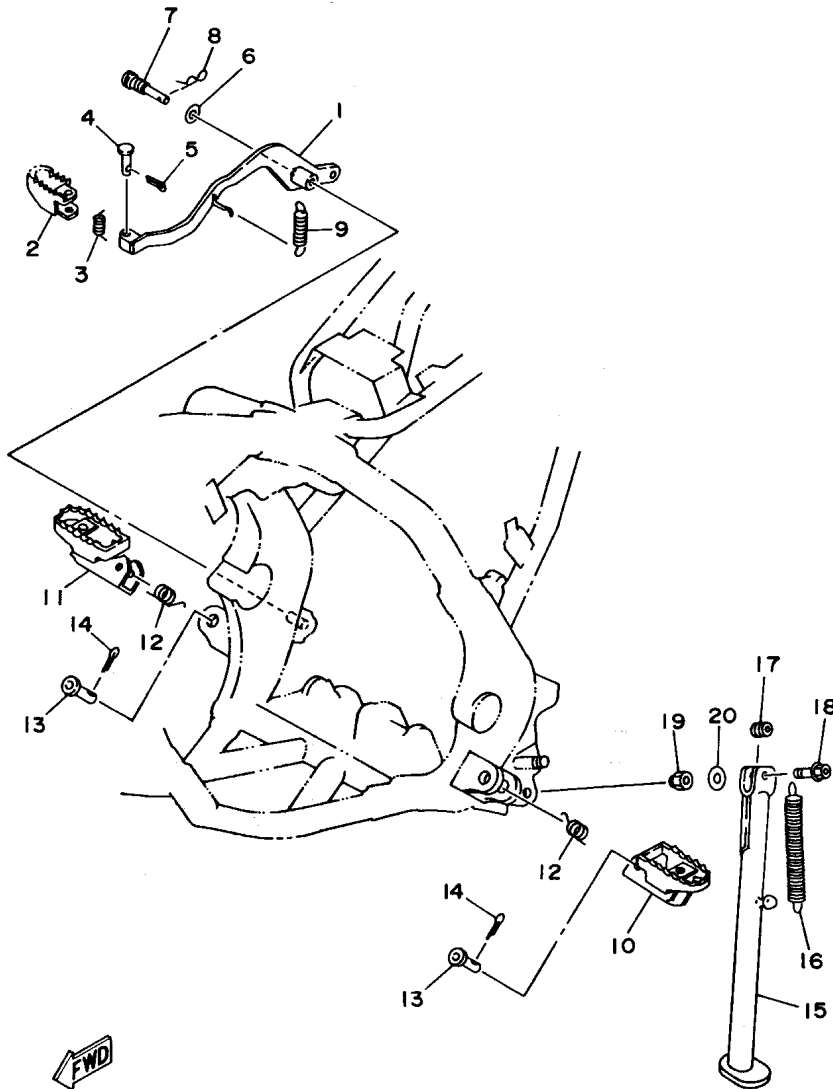
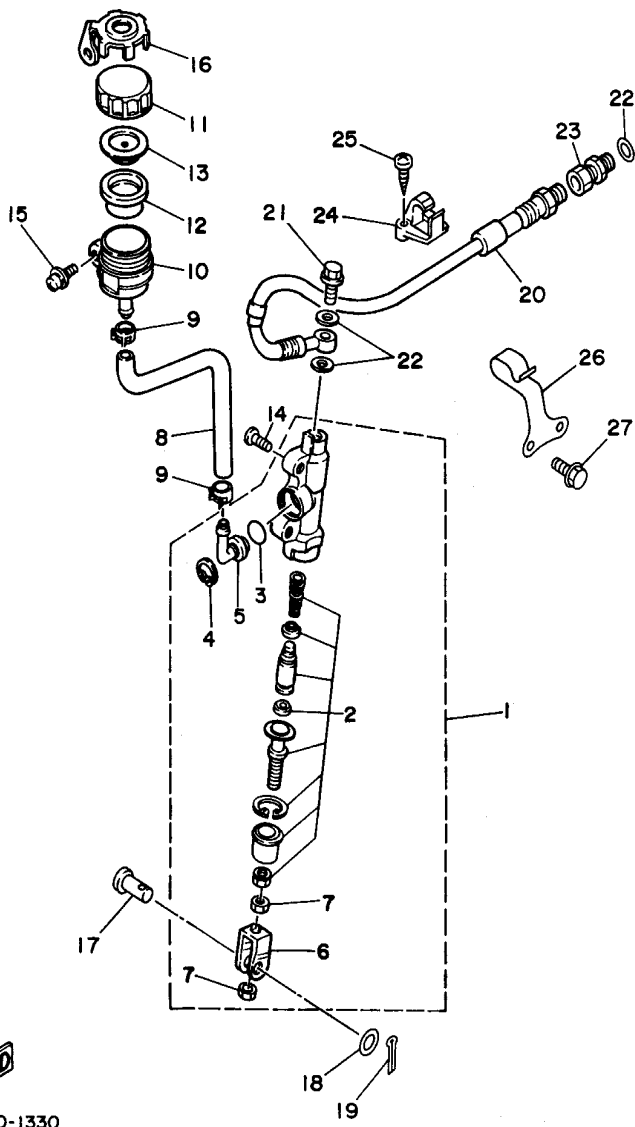

FIG. 31 STAND. FOOTREST

REF. NO.	PART NO.	DESCRIPTION	Q'TY	REMARKS
1	3XP-27211-00	PEDAL, BRAKE	1	
2	3XP-27242-00	PEDAL, BRAKE	1	
3	90508-14352	SPRING, TORSION	1	
4	91701-06022	PIN, CLEVIS	1	
5	91490-20020	PIN, COTTER	1	
6	90201-086P8	WASHER, PLATE	1	
7	90149-08269	SCREW	1	
8	90468-10050	CLIP	1	
9	90506-14453	SPRING, TENSION	1	
10	3LD-27411-00	FOOTREST 1	1	
11	3LD-27421-00	FOOTREST 2	1	
12	90508-28777	SPRING, TORSION	2	
13	90240-10117	PIN, CLEVIS	2	
14	91401-25020	PIN, COTTER	2	
15	3XP-27311-10	STAND, SIDE	1	
16	90506-35474	SPRING, TENSION	1	
17	90387-10036	COLLAR	1	
18	90105-10728	BOLT, WASHER BASED	1	
19	90185-10120	NUT, SELF-LOCKING	1	
20	92990-10200	WASHER, PLAIN	1	

48F4300-5310

D14



3XP1010-1330

FIG. 32 REAR MASTER CYLINDER

REF. NO.	PART NO.	DESCRIPTION	Q'TY	REMARKS
1	3XP-2583V-00	RR. MASTER CYLINDER ASSY	1	
2	3BN-W0042-50	.CYLINDER KIT, MASTER	1	
3	93210-15620	.O-RING	1	
4	2VN-25866-00	.CIRCLIP	1	
5	2VN-2582A-50	.JOINT	1	
6	2YK-27222-00	.JOINT	1	
7	95307-08600	.NUT	2	
8	3XP-25895-00	HOSE, RESERVOIR	1	
9	90467-11044	CLIP	2	
10	2VN-25894-00	TANK, RESERVOIR	1	
11	3XP-25852-50	CAP, RESERVOIR	1	
12	2VN-25854-00	DIAPHRAGM, RESERVOIR	1	
13	2VN-25855-00	BUSH, DIAPHRAGM	1	
14	92017-08016	BOLT, BUTTON HEAD	2	
15	90159-06056	SCREW, WITH WASHER	1	
16	3ET-25888-00	COVER, RESERVOIR TANK	1	
17	90240-08124	PIN, CLEVIS	1	
18	90201-08083	WASHER, PLATE	1	
19	91401-16020	PIN, COTTER	1	
20	3XP-25873-02	HOSE, BRAKE 2	1	
21	90401-10159	BOLT, UNION	1	
22	90201-10118	WASHER, PLATE	3	
23	3LC-25885-00	JOINT	1	
24	3BN-25876-00	HOLDER, BRAKE HOSE 2	1	
25	97707-50516	SCREW, TAPPING	2	
26	90462-12195	CLAMP	1	
27	95027-06008	BOLT	2	

D15

FIG. 33 GENERATOR

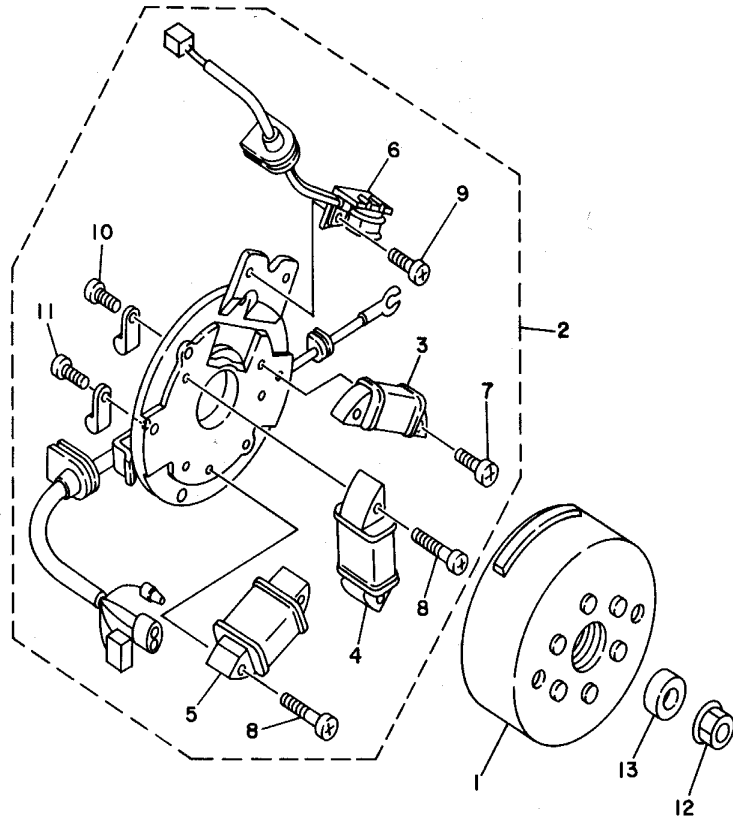

REF. NO.	PART NO.	DESCRIPTION	Q'TY	REMARKS
1	4BF-85550-00	ROTOR ASSY	1	
2	4BF-85560-00	BASE ASSY	1	
3	37A-85520-M1	.COIL, CHARGE	1	
4	4BF-81313-00	.COIL, LIGHTING 1	1	
5	4BF-81314-00	.COIL, LIGHTING 2	1	
6	4BF-85595-00	.COIL, PULSER	1	
7	98503-04014	.SCREW, PAN HEAD	2	
8	98511-04025	.SCREW, PAN HEAD	4	
9	98580-04008	.SCREW, PAN HEAD	2	
10	97601-04106	.SCREW, PAN HEAD WITH WASHER	3	
11	98511-04006	.SCREW, PAN HEAD	1	
12	90179-12248	NUT	1	
13	90201-123L6	WASHER, PLATE	1	



4BF1100-2330

E2

FIG. 34 METER

REF. NO.	PART NO.	DESCRIPTION	Q'TY	REMARKS
1	4BF-83500-10	SPEEDOMETER ASSY	1	
2	3R8-83578-00	.KNOB, TRIP METER	1	
3	90157-02031	.SCREW, PAN HEAD	1	
4	95807-06018	BOLT, FLANGE	2	
5	3XP-83550-00	SPEEDOMETER CABLE ASSY	1	

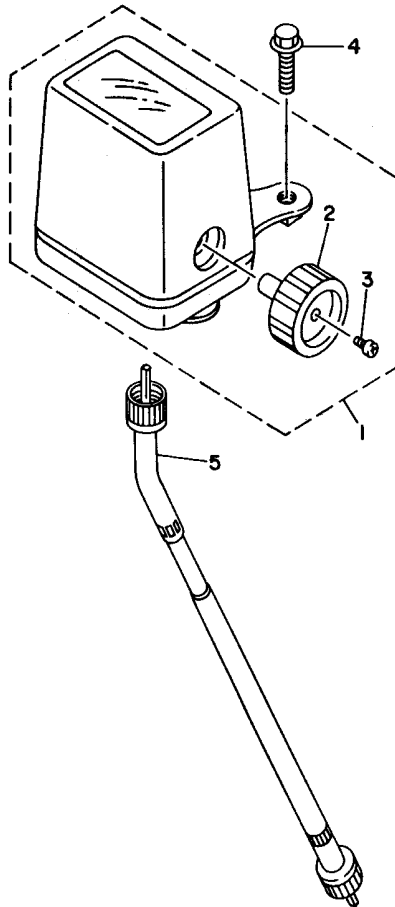

4BF1100-2340

E3



FIG. 35 HEADLIGHT

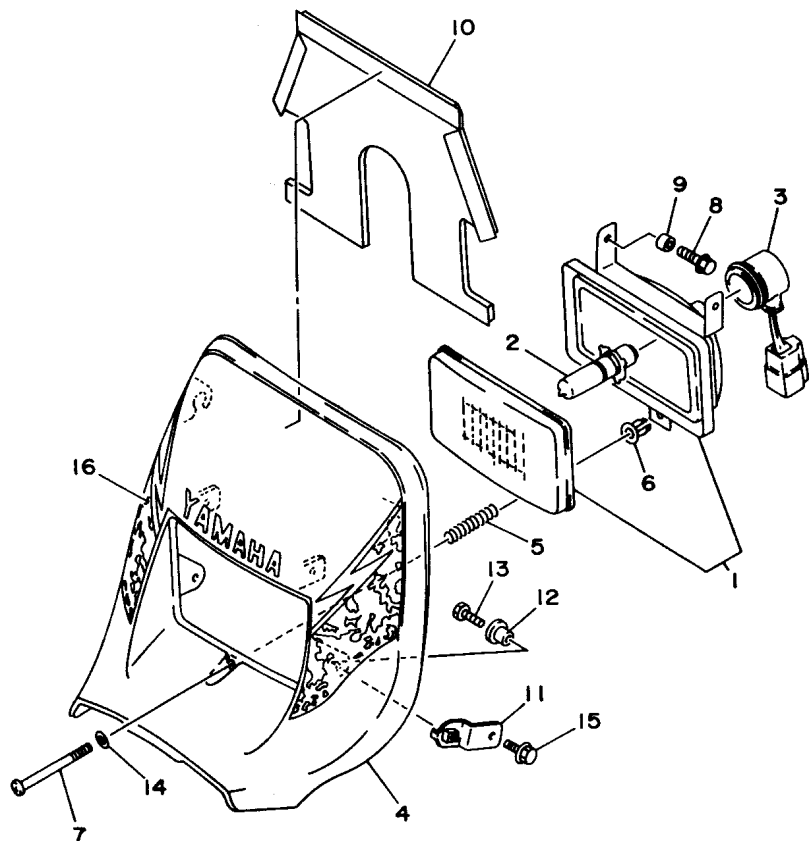

REF. NO.	PART NO.	DESCRIPTION	Q'TY	REMARKS
1	3XP-84320-00	LENS ASSY	1	
2	3FW-84314-00	BULB, HEADLIGHT	1	
3	3FW-84340-00	SOCKET CORD ASSY 1	1	
4	3XP-84311-00	BODY, HEADLIGHT	1	
5	55U-84332-00	SPRING, SCREW	1	
6	50W-84334-00	NUT, ADJUSTING	1	
7	849-84724-00	SCREW, LENS FITTING	1	
8	55U-84337-00	BOLT, SPECIAL	2	
9	55U-84328-00	SPACER	2	
10	3XP-84196-00	COVER, SOCKET	1	
11	3XP-84118-00	STAY, HEADLIGHT 1	2	
12	3XP-84145-00	COLLAR, BODY FITTING	2	
13	97016-06016	BOLT	2	
14	92901-04600	WASHER, PLATE	1	
15	95817-06012	BOLT, FLANGE	2	
16	4BF-28391-00	EMBLEM, HEADLIGHT	1	



4BF3300-4350

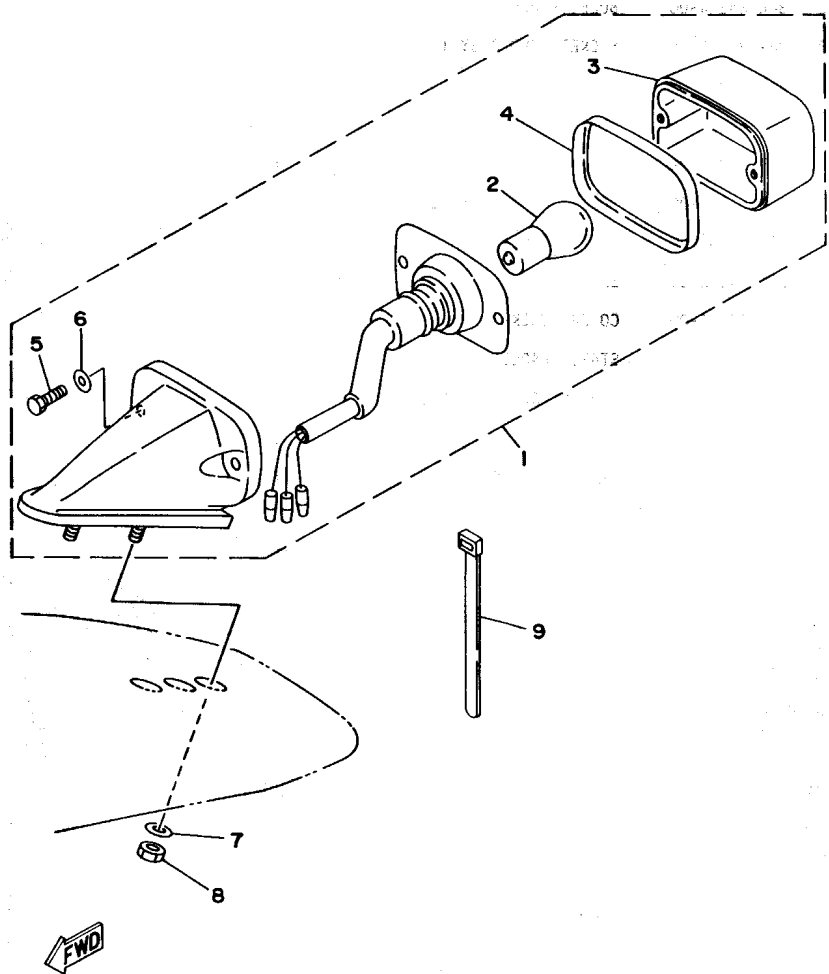

4BF1100-2360

FIG. 36 TAILLIGHT

REF. NO.	PART NO.	DESCRIPTION	Q'TY	REMARKS
1	4BF-84700-00	TAILLIGHT ASSY	1	
2	27V-84714-00	.BULB (12V-18/5W)	1	
3	434-84521-69	.LENS, TAILLIGHT	1	
4	434-84515-61	.RIM, TAILLIGHT	1	
5	434-84552-62	.BOLT, FITTING	2	
6	434-84522-62	.WASHER	2	
7	92907-05600	WASHER, PLATE	2	
8	95607-05100	NUT, U	2	
9	1UA-82591-00	BAND	1	

E5

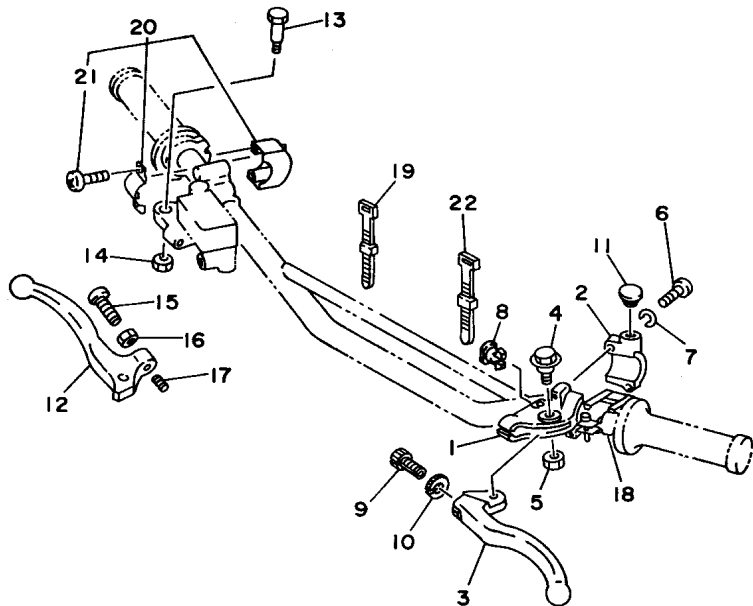

FIG. 37 HANDLE SWITCH. LEVER

REF. NO.	PART NO.	DESCRIPTION	Q'TY	REMARKS
1	1LN-82911-00	HOLDER, LEVER 1	1	
2	33G-82913-00	HOLDER, LEVER LOWER 1	1	
3	23X-83912-00	LEVER 1	1	
4	90109-06799	BOLT	1	
5	95607-06100	NUT, U	1	
6	98507-05020	SCREW, PAN HEAD	2	
7	92907-05100	WASHER	2	
8	503-83956-00	CAP 1	1	
9	90123-08046	BOLT	1	
10	90179-08148	NUT	1	
11	90338-09012	PLUG	1	
12	3JD-83922-00	LEVER 2	1	
13	90109-062A8	BOLT	1	
14	95607-06100	NUT, U	1	
15	90149-06131	SCREW	1	
16	90170-06010	NUT	1	
17	90501-10312	SPRING, COMPRESSION	1	
18	23X-83976-00	SWITCH, HANDLE 1	1	
19	437-83936-01	BAND, SWITCH CORD	2	
20	4BF-83976-00	SWITCH, HANDLE 1	1	
21	98506-04012	SCREW, PAN HEAD	2	
22	437-83936-01	BAND, SWITCH CORD	2	



4BF3300-4370

E6

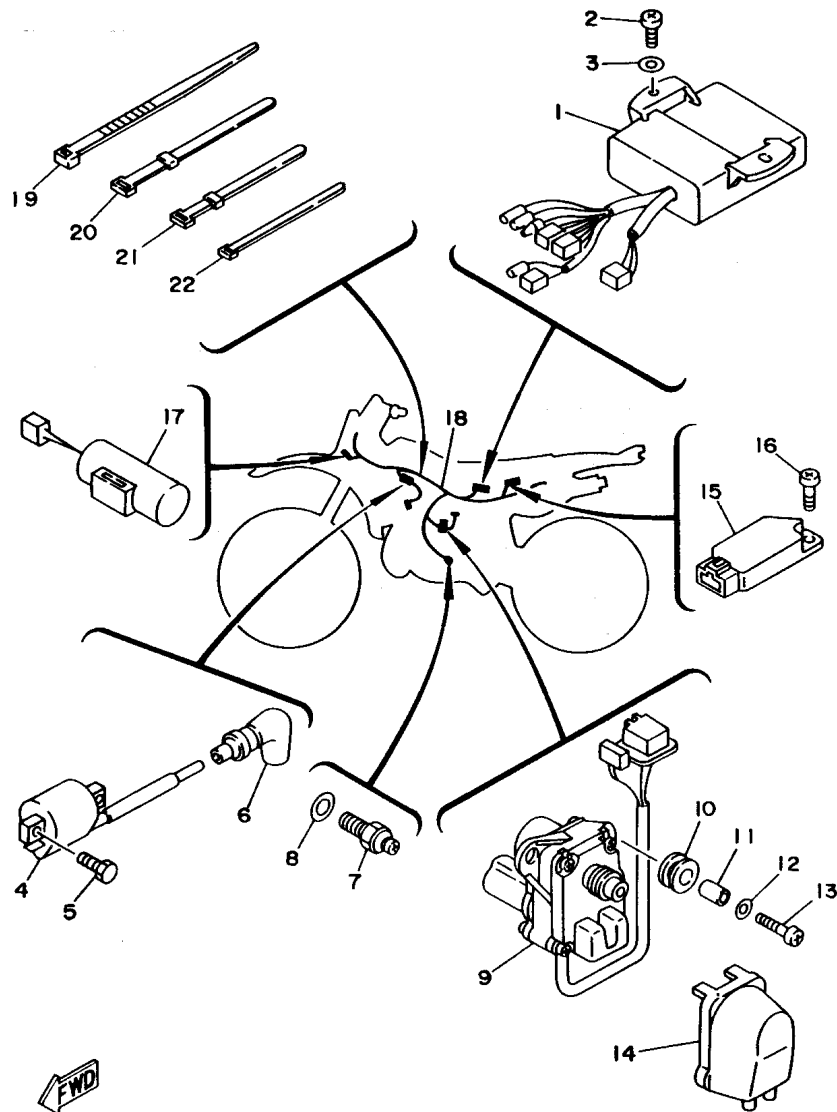

4BF4300-5380

FIG. 38 ELECTRICAL 1

REF. NO.	PART NO.	DESCRIPTION	Q'TY	REMARKS
1	4BF-85540-00	C.D.I. UNIT ASSY	1	
2	98507-06016	SCREW, PAN HEAD	2	
3	92907-06600	WASHER, PLATE	2	
4	4AC-82310-01	IGNITION COIL ASSY	1	
5	97007-06016	BOLT	2	
6	81E-82370-20	PLUG CAP ASSY	1	
7	4KM-82540-00	NEUTRAL SWITCH ASSY	1	
8	296-82543-00	GASKET	1	
9	3XP-85820-00	SERVO MOTOR ASSY	1	
10	90480-14023	GROMMET	2	
11	90387-06299	COLLAR	2	
12	90201-06765	WASHER, PLATE	2	
13	98507-06025	SCREW, PAN HEAD	2	
14	34X-85825-01	COVER, WIRE	1	
15	1JK-81960-A1	RECTIFIER & REGULATOR ASSY	1	
16	98507-06012	SCREW, PAN HEAD	2	
17	1NL-81965-01	CONDENSER, SMOOTHING	1	
18	4BF-82590-00	WIRE HARNESS ASSY	1	
19	12R-82591-00	BAND	2	
20	437-83936-11	BAND, SWITCH CORD	2	
21	437-83936-11	BAND, SWITCH CORD	1	
22	341-26397-01	BAND	1	

# **INDEX**

NUMERICAL INDEX

PART NO.	GRID NO.	PART NO.	GRID NO.	PART NO.	GRID NO.	PART NO.	GRID NO.	PART NO.	GRID NO.	PART NO.	GRID NO.
3XP-W0041-00	D-13	1LX-1248A-00	B- 8	3PA-14613-10	B-13	3BN-17161-02	C- 5	3XP-21747-00	C-12	3SP-2314G-L0	D- 5
3BN-W0042-50	D-15	3XP-12481-10	B- 7	3XP-14714-00	B-13	4BF-17211-00	C- 5	4U5-2176E-00	C-11	3SP-2314H-L0	D- 5
3XP-W0045-00	D- 9	3XP-12482-10	B- 7	3XP-14718-00	B-13	3BN-17221-00	C- 5		C-11	3XP-2314J-L0	D- 5
3XP-W0046-00	D-11	3XP-12483-10	B- 7	2GU-14752-00	B-13	3BN-17231-01	C- 5	22W-21791-00	C-11	4BF-23141-00	D- 4
3JD-W0047-00	D- 9	3XP-12484-10	B- 7	4BF-14753-00	B-13	3XP-17241-00	C- 5		C-11		D- 5
3JD-W0047-50	D-11	3XP-12485-10	B- 8	565-14771-00	B-13	3BN-17251-02	C- 5		C-12	3XP-23142-00	D- 4
36Y-W0048-00	D- 9	126-13116-01	B-15	3XP-1490J-10	B-11	3XP-17261-00	C- 5		C-12		D- 5
	D-11	3XP-13565-00	B- 9	3XP-14931-00	B-11	4BF-17411-00	C- 5	1AA-21815-00	C-13	3SP-23143-L0	D- 4
3JD-W0057-00	D- 9	3XP-13591-00	B-10	1KT-14994-00	B-11	3BN-17421-00	C- 5	26H-21828-00	C-13		D- 5
3SP-W0057-50	D-11	1LX-13610-01	B- 9	3XP-15111-00	B-14	4BF-17471-00	C- 6	3XP-21871-00	C-13	3SP-23144-L0	D- 4
3XP-11111-00	B- 2	55Y-13613-00	B- 9	3XP-15121-01	B-14	10W-18101-03	C- 8	4BF-22110-00-T9	C-14		D- 4
3XP-11181-00	B- 2	55Y-13616-00	B- 9	37F-15128-00	B-14	3XP-18110-00	C- 8	3JD-22128-00	C-14	3SP-23145-L0	D- 4
3XP-1131A-00	B- 2	3XP-13621-00	B- 9	4BF-15189-00	B-15	1W6-18113-00	C- 8	1LX-22141-00	C-14		D- 4
3RR-1131E-00	B- 2	3XP-1410A-00	B-11	3BN-15199-01	B-14	3BN-18140-00	C- 7	3JD-22147-00	C-14	36Y-23146-10	D- 4
2RH-1131M-10	B- 2	4BF-14101-00	B-11	328-15316-00	B-14	3XP-18179-00	C- 8	3XP-22151-01	C-14		D- 4
4FL-1131N-00	B- 2	3XP-14103-00	B-11	3XP-15317-00	B-14	55K-18511-01	C- 7	3JD-22156-00	C-14	26H-23156-00	D- 4
2RH-1131R-10	B- 2	3XP-14104-00	B-11	4BF-15357-00	B-15	2RH-18512-00	C- 7	3XP-2217A-00	C-14		D- 4
31K-1131U-00	B- 2	3XP-14112-40	B-11	3Y1-15361-00	B-15	55K-18513-00	C- 7	3XP-2217F-00	C-15	2HH-23158-L0	D- 4
3XP-11311-00	B- 2	8A7-14139-00	B-11	1RG-15363-00	B-15	55K-18531-00	C- 7	2HH-22178-00	C- 8		D- 5
29L-1132E-00	B- 2	3XP-14141-28	B-11	583-15371-00	B-14	3BN-18535-00	C- 7	30X-22178-00	C- 9	4BF-2316A-00	D- 4
3XP-1133E-00	B- 3	193-14142-35	B-11	3ET-15379-00	B-15	3XP-18540-00	C- 7	10V-22184-00	C- 9		D- 5
3BN-1133F-00	B- 3	137-14143-42-A1	B-11	3BN-15411-11	B-15	4BF-21110-10-G3	C- 9	30X-2219X-00	C-14	3XJ-23167-L0	D- 5
3XP-11351-00	B- 2	313-14146-00	B-11	4BF-15416-00	B-15	1JK-21268-00	C- 9	3XP-22199-03	C-14	3XP-23170-00	D- 4
3XP-11400-00	B- 4	3JD-14147-00	B-11	3XP-15421-01	B-15	3XP-2138K-00	C-11	4BF-22201-20	D- 2		D- 4
3XP-11412-00	B- 4	137-14153-00	B-11	161-15426-00	B-15	4BF-2138L-00	C-12	4BF-22210-20-P1	D- 2	3JD-23171-L0	D- 4
3XP-11422-00	B- 4	127-14161-00	B-11	3XP-15451-00	B-15	3XP-21415-00	C- 9	23X-22211-00	D- 2		D- 4
2TV-11454-00	B- 4	239-14172-08	B-12	2RH-15492-00	B-14	3XP-21425-00	C- 9	4BF-22212-00-P1	D- 2	4BF-23174-01	D- 3
55K-11530-00	B- 4	3XP-14185-00	B-11	3XP-15620-01	C- 2	2K7-2148A-00	C- 9	3XP-22214-00	D- 2	4V4-23194-L0	D- 5
10V-11536-01	B- 4	353-14186-00	B-11	3XP-15621-00	C- 2	3XP-21511-00	C-10	3XP-22224-00	D- 2	3XP-23318-00	D- 3
3XP-11610-00	B- 4	3XP-14190-30	B-11	10V-15641-00	C- 2	4BF-21611-00	C-10	3SP-22241-00	D- 2	3XP-23318-10	D- 5
3XP-11631-01-A0	B- 4	12R-14191-00	B-11	10V-15651-00	C- 2	3XP-21639-00	C-10	3XJ-22475-00	C-15	3XP-23340-00	D- 5
3XP-11631-01-B0	B- 4	3XG-14196-00	B-11	10V-15660-00	C- 2	39X-21642-00	C-10	4BF-23102-10	D- 4	3SP-23346-L0	D- 5
3XP-11631-01-C0	B- 4	3KD-14197-00	B-11	10V-15666-00	C- 2	3XP-21711-01	C-11	4BF-23103-10	D- 4	3XP-23346-00	D- 5
3XP-11631-01-D0	B- 4	3XP-14229-00	B-11	3RR-16111-00	C- 3	3XJ-21717-00	D- 6	3XP-23110-00	D- 4	3SP-23356-L0	D- 5
4H7-11633-00	B- 4	3XP-14261-00	B-11	3XP-16150-00	C- 3	3XJ-2172A-00	C-11	3XP-23111-00	D- 4	3XP-23389-00	D- 3
43G-11651-00	B- 4	3XP-14294-00	B-11	2TV-16154-00	C- 3	3XJ-2172F-00	C-12		D- 5	3XP-23389-10	D- 5
37F-11681-00	B- 4	3XP-14411-00	B- 9	21V-16321-00	C- 3	3MA-2172N-00	C-13	55Y-2312G-M0	D- 4	3XP-23416-00	D- 3
4BF-1240A-10	B- 7	3XP-14412-00	B- 9	1V1-16324-00	C- 3	3XP-21721-01	C-11		D- 5	26H-23418-01	D- 3
3BN-12414-10	B- 7	3XP-14421-00	B- 9	1HX-16331-00	C- 3	4BF-2173E-11	C-12	3XP-23120-00	D- 4	4BF-23435-01-35	D- 3
3XP-12422-10	B- 6	3AJ-1443E-00	B- 9	3VD-16340-11	C- 3	4BF-2173F-11	C-12	3JD-23125-L0	D- 4	1E6-23441-10-35	D- 3
3BN-12428-11	B- 6	43G-14436-00	B- 9	3XP-16351-00	C- 3	3XP-21731-00	C-11		D- 4	3XP-23462-00	D- 3
36F-12450-00	B- 6	3XP-14437-00	B- 9	3LD-1637A-01	C- 3	3XP-2174A-00	C-12	2KF-23127-01	D- 5	3XP-23778-00	D- 4
2TV-12459-00	B- 6	4BF-14451-00	B- 9	2TV-16371-00	C- 3	3XP-2174F-10	C-12	4JW-23138-00	D- 5		D- 5
3XP-12460-00	B- 7	3XP-14453-00	B- 9	3JD-16382-00	C- 4	4BF-2174G-00	C-12	4BF-2313C-01	D- 5	4BF-24110-00	D- 6
3XP-12462-00	B- 7	3XP-14458-00	B- 9	3BN-16383-00	C- 3	4BF-2174H-00	C-12	3XP-23136-30	D- 4	5X6-2412F-00	D- 6
3BN-12469-00	B- 7	3XP-14459-00	B- 9	3BN-17121-00	C- 5	3XP-2174T-00	C-12		D- 4	24X-24144-00	D- 6
3XP-12469-10	B- 8	3XP-14610-00	B-13	3BN-17131-01	C- 5	4BF-21741-00	C-11	4EW-2314E-L0	D- 5	4BF-24173-00	D- 6
3XP-12476-10	B- 8	2GU-14613-10	B-13	3BN-17151-01	C- 5	3XP-21746-00	C-12	3SP-2314F-L0	D- 5	1LX-24181-00	D- 6

NUMERICAL INDEX

PART NO.	GRID NO.	PART NO.	GRID NO.	PART NO.	GRID NO.	PART NO.	GRID NO.	PART NO.	GRID NO.	PART NO.	GRID NO.
3XP-24311-10	D- 6	3GD-25933-00	D- 9	437-83936-11	E- 7	90116-08318	B- 2	90179-16613	C- 5	90202-12031	C- 8
3XP-24500-00	D- 6	4EW-26111-00	D-12		E- 7	90116-08388	B- 2	90179-25614	D- 3	90202-26142	D- 3
4X8-24512-00	D- 6	3BN-26141-20	D-12	503-83956-00	E- 6	90116-08394	B- 2	90179-25615	D- 3	90208-18046	C- 3
1UY-24610-00	D- 6	3BN-26142-20	D-12	23X-83976-00	E- 6	90119-05001	C- 3	90185-08146	D-10	90209-06096	B- 9
509-24724-00	D- 7	TLX-26241-01	D-12	4BF-83976-00	E- 6	90119-06043	D- 7	90185-10060	C- 9	90209-18135	C- 5
4BF-24731-10	D- 7	1LX-26242-01	D-12	3XP-84118-00	E- 4	90119-06097	C-10	90185-10120	D-14	90209-22257	B- 4
4BF-24770-10	D- 7	322-26243-00	D-12	3XP-84145-00	E- 4	90119-06118	B-10	90185-14070	C-15	90215-12271	C- 3
55U-25104-00	D- 8	1M1-26249-01	D-12	3XP-84196-00	E- 4	90119-06194	C-10	90185-16127	C-14	90215-12272	B- 4
3XP-25111-00-35	D- 8	5X2-2628H-01	D-12	3XP-84311-00	E- 4	90119-06205	C-13	90201-06M08	C-11	90215-20283	C- 5
322-25118-00	D- 8	5X2-26281-00	D-12	3FW-84314-00	E- 4	90119-06214	D- 6		C-11	90240-08124	D-15
55U-25181-01	D- 8	322-26282-00	D-12	3XP-84320-00	E- 4	90119-06228	C-10	90201-060A3	B-13	90240-10117	D-14
3XP-25190-00	D- 8	4BF-26311-00	D-12	55U-84328-00	E- 4	90122-06013	B- 9	90201-062A8	C-11	90267-40080	B- 9
2VN-25304-00	D-10	3XP-26335-00	D-12	55U-84332-00	E- 4	90123-08046	E- 6		C-11	90280-03017	B- 4
3XP-25311-00-35	D-10	1E6-26342-00	D-12	50W-84334-00	E- 4	90149-06011	D- 6	90201-063J2	B- 7	90282-05047	B- 4
3GB-25367-00	D-10	341-26397-01	C-13	55U-84337-00	E- 4	90149-06131	E- 6		B- 7	90282-05058	B- 4
3XP-25381-00	D-10		E- 7	3FW-84340-00	E- 4	90149-06165	D- 6	90201-06765	E- 7	90338-09012	D-13
3BN-25388-00	D-10	157-27114-00	B-13	434-84515-61	E- 5	90149-06200	B- 9	90201-08083	D-15		E- 6
3BN-25389-00	D-10	3XP-27211-00	D-14	434-84521-69	E- 5	90149-06223	C-11	90201-08087	B-15	90338-10150	C-14
2X3-25394-00	D-10	2YK-27222-00	D-15	434-84522-62	E- 5		C-11	90201-08326	B-13	90338-16029	B-14
5X2-25394-00	D- 8	3XP-27242-00	D-14	434-84552-62	E- 5	90149-06305	C-11	90201-08512	B- 6	90380-22111	C-14
2YY-25452-00	D-10	3XP-27311-10	D-14	4BF-84700-00	E- 5		C-11	90201-086P8	D-14	90387-062M9	C-11
3XP-2580T-01	D- 9	3LD-27411-00	D-14	27V-84714-00	E- 5	90149-08269	D-14	90201-08649	B- 2		C-11
3XP-2580W-00	D-11	3LD-27421-00	D-14	849-84724-00	E- 4	90154-05063	C-11	90201-08753	C- 9	90387-062V8	C-10
2VN-2582A-50	D-15	3JD-27491-00	D-11	37A-85520-M1	E- 2		C-11	90201-08759	C-15	90387-062A1	B-10
3XP-2582T-00	D- 9	3XP-28100-00	C- 9	4BF-85540-00	E- 7	90157-02031	E- 3	90201-10M05	C- 9	90387-06299	E- 7
3XP-2582W-00	D-11	1AE-2834F-00	B-10	4BF-85550-00	E- 2	90157-05079	C-12	90201-10118	D-13	90387-06387	D- 6
3XP-2583T-00	D-13	4BF-28391-00	E- 4	4BF-85560-00	E- 2	90157-06115	B-15		D-15	90387-06500	D-12
3XP-2583V-00	D-15	4BF-81313-00	E- 2	4BF-85595-00	E- 2	90159-05061	C-11	90201-10119	C- 3	90387-06737	B-10
2KF-25852-01	D-13	4BF-81314-00	E- 2	3XP-85820-00	E- 7	90159-05117	C-11	90201-106F2	C-15	90387-07392	B- 7
3XP-25852-50	D-15	1JK-81960-A1	E- 7	34X-85825-01	E- 7	90159-05183	C-11	90201-120E8	C- 3	90387-07573	B- 7
2VN-25854-00	D-15	1NL-81965-01	E- 7	90101-06576	B-13		C-11	90201-123L6	E- 2	90387-100Y3	D- 2
55U-25854-00	D-13	1KH-82131-00	C- 9	90105-06601	C-14		C-13	90201-12474	C- 3	90387-1003G	D-14
2VN-25855-00	D-15	4AC-82310-01	E- 7	90105-08646	C- 9	90159-06056	D-15	90201-12631	C- 2	90387-103X9	C-15
2VN-25866-00	D-15	81E-82370-20	E- 7	90105-08659	D- 9	90159-06160	C-11	90201-150H2	C- 3	90387-105L0	B-13
56A-25867-00	D-13	4KM-82540-00	E- 7	90105-08663	C- 9		C-11	90201-154E8	C- 2	90387-15600	D- 8
4BF-25872-01	D-13	296-82543-00	E- 7		C- 9	90170-06010	E- 6		C- 5	90387-166X0	C-14
3XP-25873-02	D-15	4BF-82590-00	E- 7	90105-10614	D- 2	90170-12370	B- 5	90201-160F6	C-15	90387-166X1	C-15
3XP-25875-00	D- 9	1UA-82591-00	E- 5	90105-10645	C- 9		C- 3	90201-164H4	C-14	90387-166X2	C-14
3BN-25876-00	D-15	12R-82591-00	E- 7	90105-10728	D-14	90171-18053	D-10	90201-170M2	B-14	90387-166X3	C-14
3LC-25885-00	D-15	1LN-82911-00	E- 6	90109-062A8	E- 6	90176-08040	B- 2	90201-180P2	C- 3	90387-202T9	B- 4
3ET-25888-00	D-15	33G-82913-00	E- 6	90109-063F7	C- 7	90176-22050	D- 3	90201-200J7	C- 2	90387-202U8	D-10
3XP-2589E-00	C-13	4BF-83500-10	E- 3	90109-06418	C- 3	90179-08148	E- 6	90201-20266	C- 5	90387-205W8	C- 5
2VN-25894-00	D-15	3XP-83550-00	E- 3	90109-065F3	D- 9	90179-08270	B-13	90201-204M9	D-10	90387-206X8	D-10
3XP-25895-00	D-15	3R8-83578-00	E- 3		D-11	90179-08491	B- 2	90201-22555	C- 5	90387-22660	D-12
3XP-25895-50	C-13	23X-83912-00	E- 6	90109-06799	E- 6	90179-10649	C-15	90201-251F6	C-14	90401-10159	D-13
3SP-25919-01	D- 9	3JD-83922-00	E- 6	90109-085E2	B-13	90179-12248	E- 2	90201-254H8	C-14		D-15
3SP-25919-51	D-11	437-83936-01	E- 6	90109-08618	D-10	90179-12659	C- 2	90202-05187	B-13	90401-14147	C-15
3SP-25924-51	D-11		E- 6	90116-08042	B-13		C- 3		D- 6	90430-06014	C- 3

NUMERICAL INDEX

PART NO.	GRID NO.	PART NO.	GRID NO.	PART NO.	GRID NO.	PART NO.	GRID NO.	PART NO.	GRID NO.	PART NO.	GRID NO.
90430-06166	B- 6	90508-14767	C- 3	93210-19123	B-15	95027-06014	D- 6	98507-05020	E- 6		
	B- 7	90508-26561	C- 7	93210-30734	B- 2	95027-06020	B- 9	98507-06010	C-13		
	B- 7	90508-26667	C- 2	93306-00438	D-10	95027-06025	B- 7	98507-06012	B- 7		
90445-09304	D- 6	90508-28777	D-14	93306-20209	D- 8		B- 7		B- 7		
90445-094F0	C-13	90508-32553	C- 8	93306-20211	C- 5	95027-08012	C- 9		B-14		
90446-07349	B-14	90560-15290	D- 8	93306-20335	B- 4		C-12		B-15		
90450-15041	B- 8	90560-20278	D-10	93306-20469	C- 5	95027-08035	D- 3		C- 6		
90450-17036	B- 8	91317-05010	B- 2	93306-30210	B- 4	95027-08040	D- 3		D- 6		
90450-22052	B- 7	91317-05012	B- 2	93306-30439	C- 5	95027-08045	C-12		E- 7		
	B- 8		B- 2	93306-30556	B- 4	95027-08050	C- 9	98507-06016	E- 7		
	B- 8	91401-16020	D-15	93310-316C9	B- 4	95307-08600	D-15	98507-06025	B- 6		
90450-28014	B- 7	91401-25020	D-14	93310-523D2	B- 4	95607-05100	E- 5		E- 7		
	B- 7	91401-30030	D-10	93311-31567	C- 5	95607-06100	D-12	98507-06030	B-15		
	B- 8	91490-20020	D-14	93315-10838	C- 4		E- 6	98507-06035	D-12		
	B- 8	91701-06022	D-14	93315-22046	C-14		E- 6	98507-06040	B-15		
90450-49020	B- 9	92014-06012	D-11		C-14	95617-08100	C- 9	98507-06050	B-14		
90450-99013	B- 9	92017-08016	D-15	93315-31502	C- 4	95617-08200	C- 9	98507-06060	B-14		
90460-32182	B-10	92901-04600	E- 4	93317-32231	C-14		C- 9	98507-06065	B- 6		
90460-37026	B-13	92902-04100	B-11	93332-00067	D- 3	95617-10200	D- 2		B-14		
90460-61063	B-10	92907-04600	B- 9	93332-00068	D- 3	95701-10500	D- 5	98507-06070	B-14		
90462-08201	B- 2	92907-05100	E- 6	93340-21505	C- 3	95707-06500	C-14	98507-08010	B-14		
90462-12195	D-15	92907-05600	E- 5	93399-99935	C-15	95807-06010	B- 8	98511-04006	E- 2		
90467-08003	C-13	92907-06100	B- 2	93399-99936	D- 2	95807-06014	C-14	98511-04012	B-11		
	D- 6		D- 6	93410-20038	C- 5	95807-06018	E- 3	98511-04025	E- 2		
90467-10008	D-15		B- 2	93410-22039	C- 5	95807-06022	D-13	98517-06020	B- 7		
90467-11044	B- 9	92907-06600	B- 2	93430-08007	C- 2	95807-08080	B-15	98580-03008	D- 6		
90467-15012	D-14		B-13	93440-30113	C-15	95817-06010	B- 7	98580-04008	E- 2		
90468-10050	D- 6		D-12		D- 2		B- 7	98580-05014	B-11		
90468-15064	C- 2		D-12	93450-17129	B- 4	95817-06012	B-13	98707-04012	D-12		
90468-26048	B- 9	92990-03100	E- 7	93507-32031	C- 2		D- 3		D-13		
90480-08216	B-15	92990-10200	B- 9	93603-22028	B- 6		E- 4	98707-06050	C-14		
90480-09481	D-10	93101-12060	D-14	93604-10011	C-15	95817-06045	C-15	98907-06010	B-13		
90480-10068	D- 3	93102-15212	C- 8	93700-06M03	C-15	95817-10016	C-15		B-13		
90480-12053	B-10	93102-20281	C- 3	93700-06005	C-15	95827-06025	B- 6	98980-06020	D- 6		
90480-12067	C-10	93102-20309	D- 8	9383A-13031	C- 5		B-13	99006-10600	C- 8		
90480-13398	E- 7	93102-25331	C- 2	94108-217X2	D- 8	97007-06016	E- 7	99009-10400	C- 3		
90480-14023	B- 7	93102-26042	B- 4	94110-180Y2	D-10	97016-06016	E- 4		C- 7		
90480-15064	B- 7	93103-10168	C- 5	94211-18176	D-10	97017-06020	C- 8	99009-15400	C- 2		
90480-18276	D- 6	93103-32099	B- 6	94227-21123	D- 8	97027-06018	B- 2		C- 5		
90480-18354	B-13	93106-22019	B- 4	94307-21145	D- 8	97601-04106	E- 2	99080-07600	B- 6		
90480-18411	D- 6	93106-28023	C-14	94309-18146	D-10	97707-50516	D-15	99247-00080	C-10		
90501-080J1	E- 6	93108-23010	D-10	94416-21430	D- 8	97707-50520	B- 9	99510-10114	B- 2		
90501-10312	C- 2	93108-35004	B- 2	94418-18452	D-10	98503-04014	E- 2	99510-12016	B-14		
90501-12081	C- 3	93109-20029	C-14	94581-47116	D-10	98506-04012	E- 6	99530-10014	B-15		
90501-20568	D-14	93210-11313	C-14	94681-47011	D-10	98507-03008	B- 9				
90506-14453	D-14	93210-15620	B-14	94701-00188	B- 2	98507-05012	D- 3				
90506-35474	D-14	93210-16500	D-15	95027-06008	D-15	98507-05014	B-15				
90508-14352	D-14		B- 7	95027-06012	D- 3	98507-05016	D-12				



*COPY RIGHT: All rights reserved. No part of this publication  
may be reproduced without permission.*

**YAMAHA**

YAMAHA MOTOR CO., LTD.

2500 SHINGA I IWATA SHIZUOKA JAPAN  
SERVICE INFORMATION DIV.

---

Printed in Japan  
First edition SEP., 1994