

PARTS CATALOGUE

- YZ80N** (4ESA) U.S.A., CANADA, EUROPE, SOUTH AFRICA
YZ80 (4ESC) JAPAN
YZ80LW (4LC8) EUROPE
YZ80LW (4LCA) JAPAN
-

YAMAHA
GENUINE
Parts & Accessories

114ES-100E1

A2

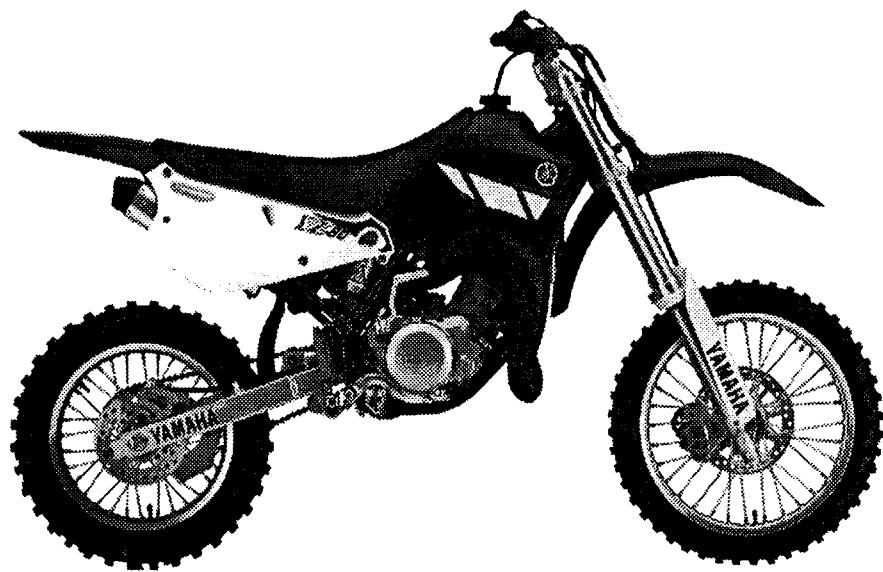

A3

FOREWORD

This Parts Catalogue is related to the parts for the model(s) in the below frame. When you are ordering replacement parts, please refer to this Parts Catalogue and quote both part numbers and part names correctly.

YZ80N(4ESA), YZ80(4ESC), YZ80LW(4LC8/4LCA)

1. Modifications or additions which have been made after issue of the Parts Catalogue will be announced in the Yamaha Parts News. It is advisable that you make necessary corrections to the Parts Catalogue according to the Yamaha Parts News.

2. Abbreviations

The Following abbreviations are used in this Parts Catalogue.

"UR" Use specified parts number.

"UN" Use as many as needed.

"AP" Alternate Parts

"LM" Local Made (Parts need to be ordered locally)

"F#" Frame No. (Applicable machine No.)

3. Parts, which are to be supplied in an assembly, are listed with a dot(.) in front of the part name as shown below.

EXAMPLE

CARBURETOR ASSY

.JET, PILOT

.NOZZLE, MAIN

4. Number of component for assembly

The numeral appearing to the right of each component part indicates the quantity of parts for each assembly unit.

EXAMPLE

PART NO.	DESCRIPTION	Q'TY	REMARKS
2F5-83310-60	FRONT FLASHER LIGHT ASSY	2	
115-83311-60	.BULB (6V-18W)	1	
1M1-83309-60	.REFLECTOR	1	

5. Applicable colors of graphics are represented in the "REMARKS" as shown below.

PART NO.	DESCRIPTION	Q'TY	REMARKS
2N4-24110-00-X5	.FUEL TANK COMP.	2	MXR
3J1-24240-10	.GRAPHIC, FUEL TANK	1	for MXR

6. Applicable Serial No.

Engine Serial No.

Frame Serial No.

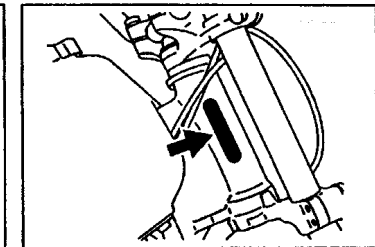
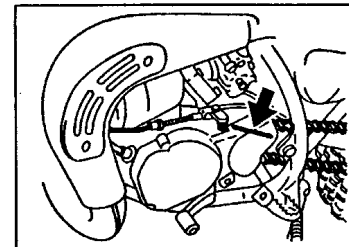

7. Note that the illustrations for reference in finding parts numbers, not to be used for assembling. When assembling, please use the applicable service manual.

8. The asterisk (*) before a reference number indicates modification items after the first edition.

MODEL LABEL

(1) A label called "Model Label" is affixed in the location as indicated in (3) below.
 When using this parts catalogue, please be sure to cross-refer the "model code - production code No." in the catalogue to the "model code - production code No." indicated on the Model Label affixed onto the product concerned.

(2) "Model Label" Indication

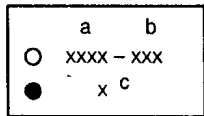

a: Model Type Code
 b: Production Code No.
 c: Colouring Type

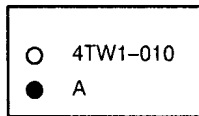

(3) Model Label Affixing Location

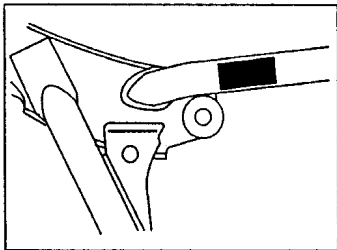

(4) Model Code - Production Code Number of Model Listed in This Parts Catalog

Model Code	Production Code No.	Country (destination)	Model Code	Production Code No.	Country (destination)
4ESA	010	U.S.A.	4LC8	070	SWEDEN
	020	CANADA	4LCA	010	JAPAN
	030	GERMANY			
	040	SPAIN			
	050	FRANCE			
	060	ENGLAND			
	070	ITALY			
	090	SWEDEN			
	100	SOUTH AFRICA			
	4ESC	010	JAPAN		
4LC8	020	GERMANY			
	030	SPAIN			
	040	FRANCE			
	050	ENGLAND			
	060	ITALY			

(5) Colouring Information

Model Code	Colouring type code	Colour code	Colour Name	Abbreviation
4ESA 4ESC 4LC8 4LCA	A	0583	DEEP PURPLISH BLUE SOLID E	DPBSE

CONTENTS

ENGINE

CYLINDER	B2
CRANKSHAFT. PISTON	B3
WATER PUMP	B4
RADIATOR. HOSE	B5
INTAKE	B6
CARBURETOR	B7
EXHAUST	B9
CRANKCASE	B10
CRANKCASE COVER 1	B11
STARTER	B12
CLUTCH	B13
TRANSMISSION	B14
SHIFT CAM. FORK	C2
SHIFT SHAFT	C3

CHASSIS

FRAME	C4
FENDER	C5
SIDE COVER	C6
REAR ARM	C7
REAR SUSPENSION	C9
STEERING	C10
FRONT FORK	C11
FUEL TANK	C13
SEAT	C14
FRONT WHEEL	C15
FRONT BRAKE CALIPER	D2
REAR WHEEL	D3
REAR BRAKE CALIPER	D5
STEERING HANDLE. CABLE	D6
FRONT MASTER CYLINDER	D7
STAND. FOOTREST	D8

REAR MASTER CYLINDER	D9
GENERATOR	D10
HANDLE SWITCH. LEVER	D11
ELECTRICAL 1	D12
ALTERNATE (CHASSIS)	D13
OPTIONAL PARTS 1	D14

INDEX

NUMERICAL INDEX	M1
-----------------------	----

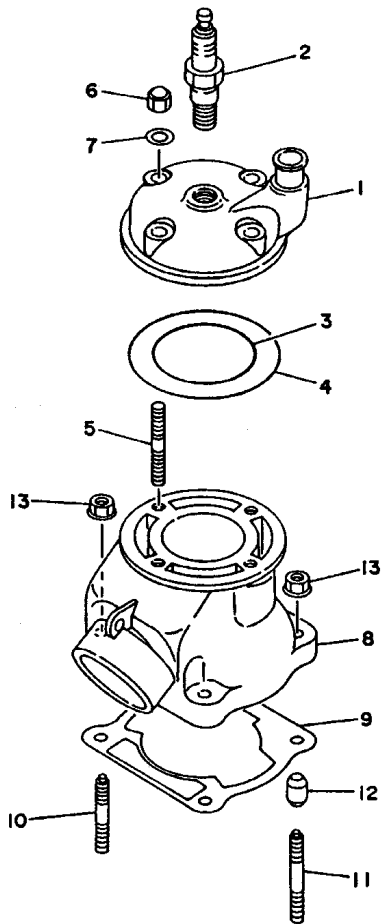

FIG. 1 CYLINDER

REF. NO.	PART NO.	DESCRIPTION	4ESA	4ESC	4LCB	4LCA	REMARKS
1	4LC-11111-00	HEAD, CYLINDER 1	1	1	1	1	
2	94702-00368	PLUG, SPARK (NGK BR10EG)	1	1	1	1	
	90793-20136	PLUG, SPARK (NGK BR10EG)		1	1	1	
3	93210-56459	O-RING	1	1	1	1	
4	93210-84724	O-RING	1	1	1	1	
5	90116-08394	BOLT, STUD	4	4	4	4	
6	90176-08026	NUT, CROWN	4	4	4	4	
7	90201-08087	WASHER, PLATE	4	4	4	4	
8	4ES-11311-10	CYLINDER 1	1	1	1	1	
9	4ES-11351-00	GASKET, CYLINDER	1	1	1	1	
10	90116-08318	BOLT, STUD	2	2	2	2	
11	90116-08388	BOLT, STUD	2	2	2	2	
12	99530-10114	PIN, DOWEL	2	2	2	2	
13	90179-08299	NUT	4	4	4	4	

4ES1100-3010

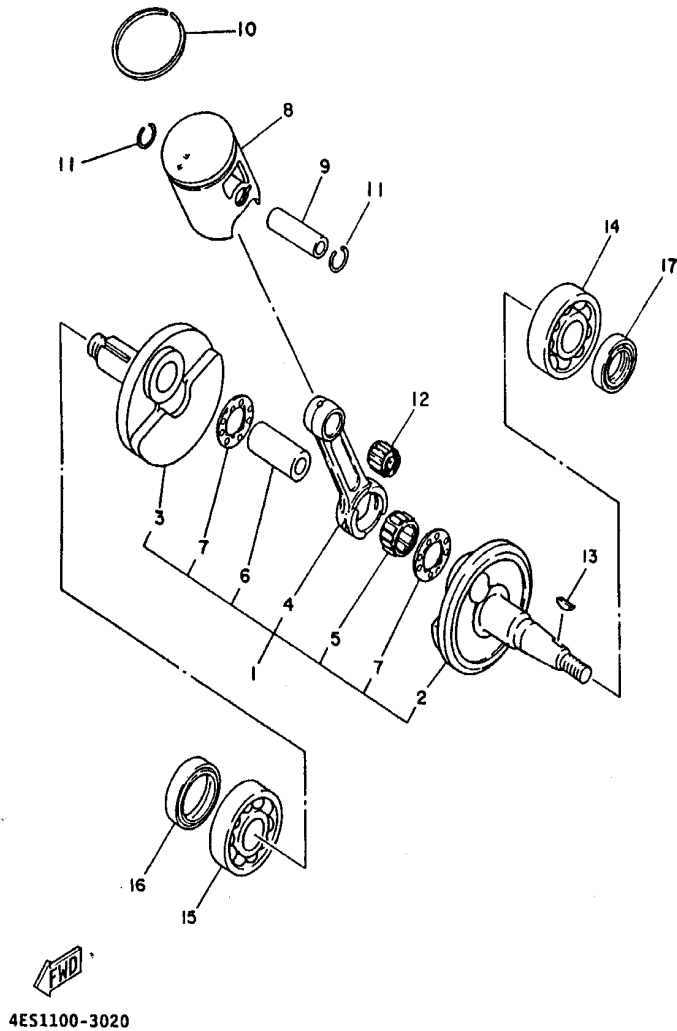
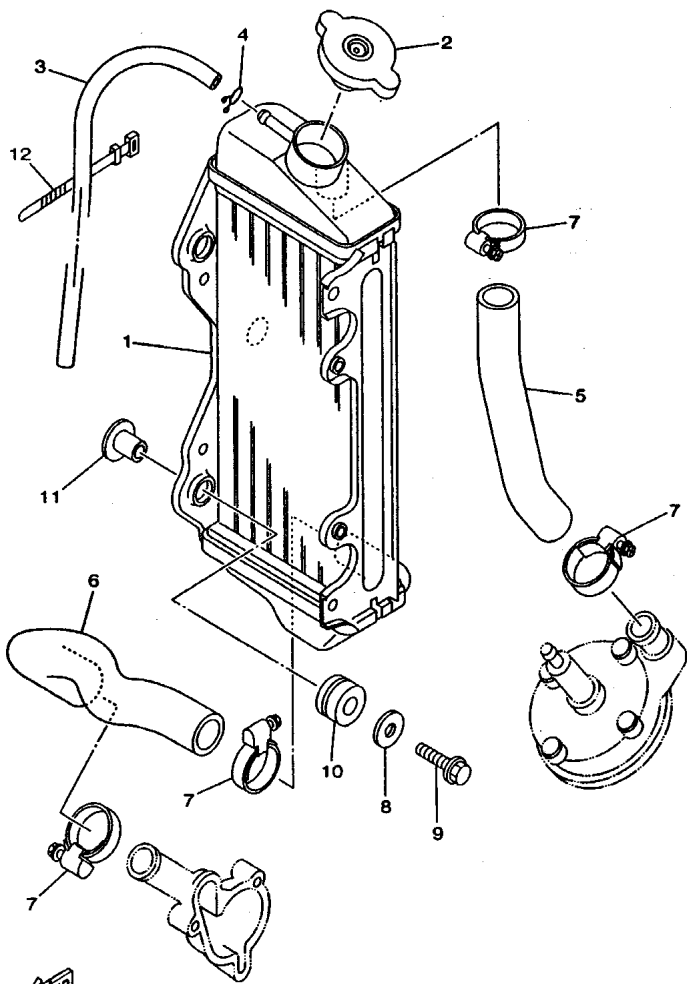

FIG. 2 CRANKSHAFT. PISTON

REF. NO.	PART NO.	DESCRIPTION	4ESA	4ESC	4LCB	4LCA	REMARKS
1	4ES-11400-02	CRANKSHAFT ASSY	1	1	1	1	
2	4ES-11412-00	.CRANK 1	1	1	1	1	
3	4ES-11422-00	.CRANK 2	1	1	1	1	
4	4ES-11651-01	.ROD, CONNECTING	1	1	1	1	
5	93310-320T3	.BEARING	1	1	1	1	
6	2RA-11681-00	.PIN, CRANK 1	1	1	1	1	
7	90209-20159	.WASHER	2	2	2	2	
8	4ES-11631-01-A0	PISTON (STD)	1	1	1	1	UR RED
	4ES-11631-01-B0	PISTON (STD)	1	1	1	1	UR ORANGE
	4ES-11631-01-C0	PISTON (STD)	1	1	1	1	UR GREEN
	4ES-11631-01-D0	PISTON (STD)	1	1	1	1	UR PURPLE
9	4ES-11633-00	PIN, PISTON	1	1	1	1	
10	43K-11611-00	RING, PISTON	1	1	1	1	
11	93450-16115	CIRCLIP	2	2	2	2	
12	93310-214F8	BEARING	1	1	1	1	KOYO
13	90280-03017	KEY, WOODRUFF	1	1	1	1	
14	93306-20438	BEARING	1	1	1	1	
15	93306-30421	BEARING (B6304C3)	1	1	1	1	
16	93103-28126	OIL SEAL	1	1	1	1	
17	93102-20447	OIL SEAL	1	1	1	1	

FIG. 4 RADIATOR. HOSE



4ESA100-1040

REF. NO.	PART NO.	DESCRIPTION	4ESA	4ESC	4LCB	4LCA	REMARKS
1	4ES-12461-10	RADIATOR ASSY	1	1	1	1	
2	5HD-12462-00	CAP, RADIATOR	1	1	1	1	
3	22W-12463-00	PIPE, BREATHER	1	1	1	1	
4	90467-08002	CLIP	1	1	1	1	
5	4ES-12481-00	PIPE 1	1	1	1	1	
6	4ES-12482-00	PIPE 2	1	1	1	1	
7	90450-28014	HOSE CLAMP ASSY	4	4	4	4	
8	90201-06071	WASHER, PLATE	3	3	3	3	
9	95027-06030	BOLT, FLANGE	3	3	3	3	
10	90480-15528	GROMMET	3	3	3	3	
11	90387-0614M	COLLAR	3	3	3	3	
12	437-83936-01	BAND, SWITCH CORD	1	1	1	1	

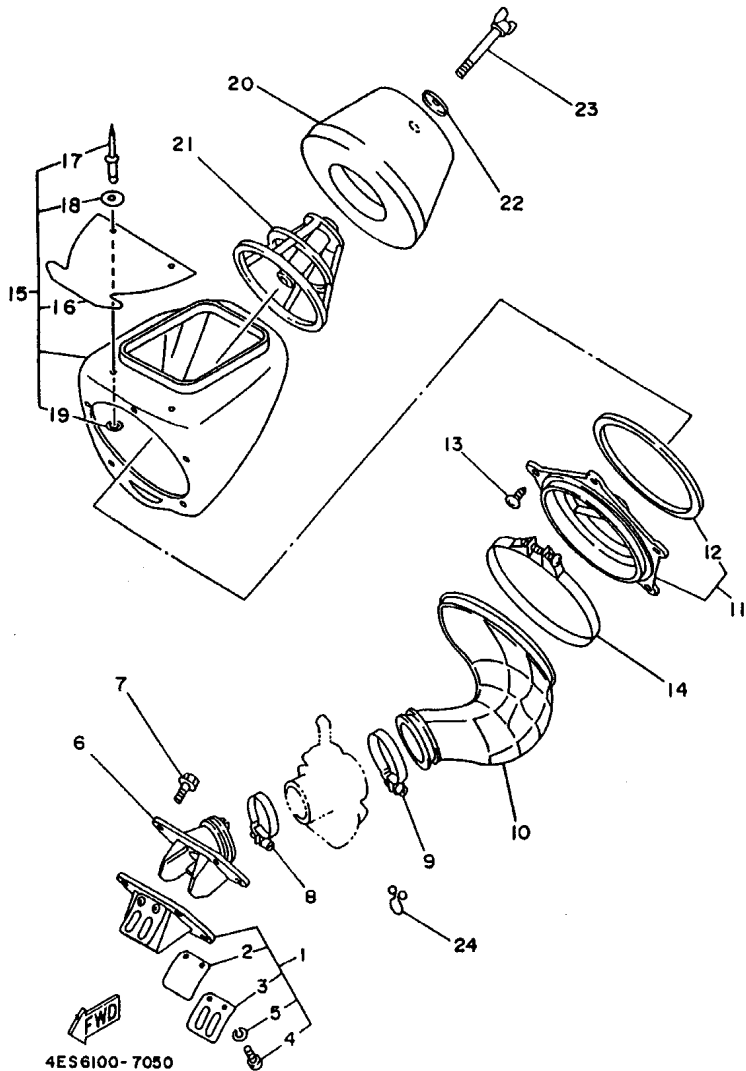
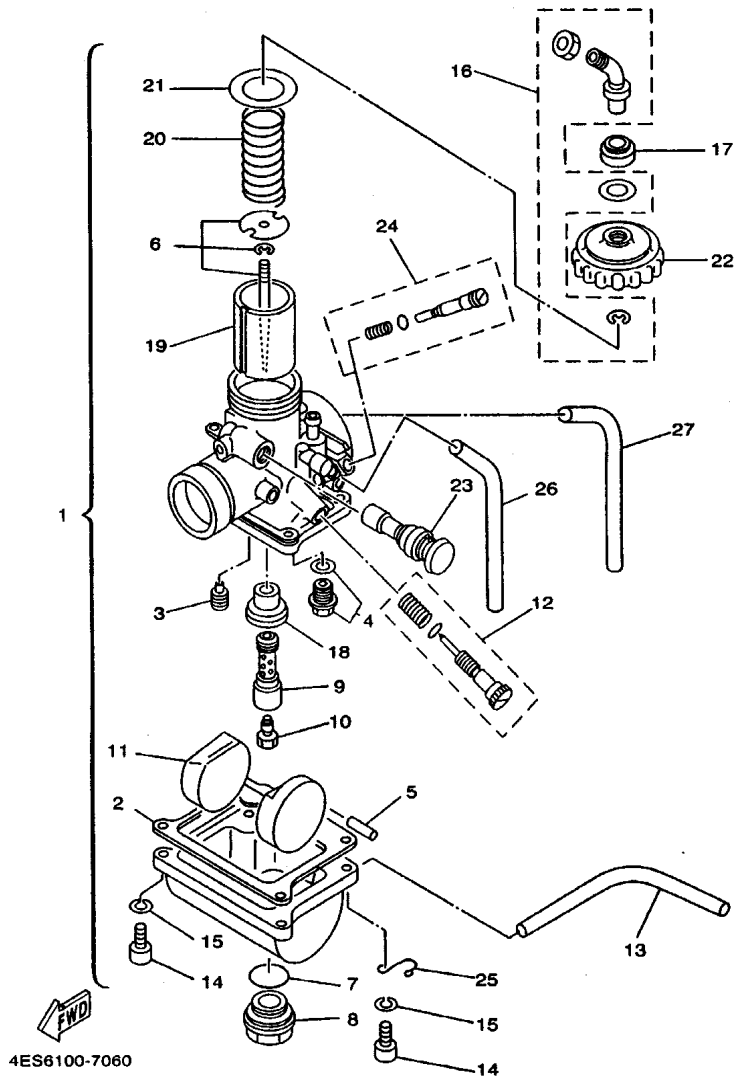

FIG. 5 INTAKE

REF. NO.	PART NO.	DESCRIPTION	4ESA	4ESC	4LCB	4LCA	REMARKS
1	4ES-13610-00	REED VALVE ASSY	1	1	1	1	
2	4ES-13613-00	.REED, VALVE	2	2	2	2	
3	4ES-13616-00	.STOPPER, REED VALVE	2	2	2	2	
4	98507-03008	.SCREW, PAN HEAD	4	4	4	4	
5	92907-03100	.WASHER	4	4	4	4	
6	4ES-13565-00	JOINT, CARBURETOR	1	1	1	1	
7	95027-06020	BOLT, FLANGE	4	4	4	4	
8	90450-45075	HOSE CLAMP ASSY	1	1	1	1	
9	90460-51059	CLAMP, HOSE	1	1	1	1	
10	4ES-14453-00	JOINT, AIR CLEANER 1	1	1	1	1	
11	4ES-14459-00	HOLDER, GUIDE	1	1	1	1	
12	4ES-14462-00	.SEAL	1	1	1	1	
13	97707-50014	SCREW, TAPPING	5	5	5	5	
14	90450-99064	HOSE CLAMP ASSY	1	1	1	1	
15	4ES-14411-01	CASE, AIR CLEANER 1	1	1	1	1	
16	4ES-14417-00	.COVER 1	1	1	1	1	
17	90267-40077	.RIVET, BLIND	2	2	2	2	
18	90201-047A2	.WASHER, PLATE	2	2	2	2	
19	92907-04600	.WASHER	2	2	2	2	
20	4ES-14451-00	ELEMENT, AIR CLEANER	1	1	1	1	
21	4ES-14458-00	GUIDE	1	1	1	1	
22	90209-06096	WASHER	1	1	1	1	
23	90122-06038	BOLT, WING	1	1	1	1	
24	90464-16039	CLAMP	1	1	1	1	

FIG. 6 CARBURETOR



REF. NO.	PART NO.	DESCRIPTION	4ESA	4ESC	4LC8	4LCA	REMARKS
1	4ES-14101-10	CARBURETOR ASSY 1	1	1	1	1	
2	304-14184-00	.GASKET, FLOAT CHAMBER	1	1	1	1	
3	260-14142-32	.JET, PILOT (# 32.5)	1	1	1	1	STD
	260-14142-30	.JET, PILOT (# 30)	1	1	1	1	AP
	260-14142-35	.JET, PILOT (# 35)	1	1	1	1	AP
4	23L-14107-25	.NEEDLE VALVE SET	1	1	1	1	
5	127-14186-00	.PIN, FLOAT	1	1	1	1	
6	58T-1490J-00	.NEEDLE SET	1	1	1	1	
7	93210-18288	.O-RING	1	1	1	1	
8	3R1-14115-00	.PLUG, SCREW	1	1	1	1	
9	3R1-14141-52	.NOZZLE, MAIN	1	1	1	1	STD
	3R1-14141-50	.NOZZLE, MAIN	1	1	1	1	AP
	3R1-14141-54	.NOZZLE, MAIN	1	1	1	1	AP
10	137-14143-60	.JET, MAIN (#300)	1	1	1	1	STD
	137-14143-58	.JET, MAIN (#290)	1	1	1	1	AP
	137-14143-62	.JET, MAIN (#310)	1	1	1	1	AP
11	314-14185-00	.FLOAT	1	1	1	1	
12	31J-14103-00	.THROTTLE SCREW SET	1	1	1	1	
13	10V-14196-00	.PIPE	1	1	1	1	
14	98507-04018	.SCREW, PAN HEAD	4	4	4	4	
15	92907-04100	.WASHER, SPRING	4	4	4	4	
16	22W-14106-00	.CABLE ADJUST SCREW SET	1	1	1	1	
17	3X3-14169-00	.CAP	1	1	1	1	
18	39K-14153-00	.WASHER, MAIN JET	1	1	1	1	
19	2X6-14112-30	.VALVE, THROTTLE 1	1	1	1	1	STD
	2X6-14112-25	.VALVE, THROTTLE 1	1	1	1	1	AP
	2X6-14112-35	.VALVE, THROTTLE 1	1	1	1	1	AP

B7

FIG. 7 EXHAUST

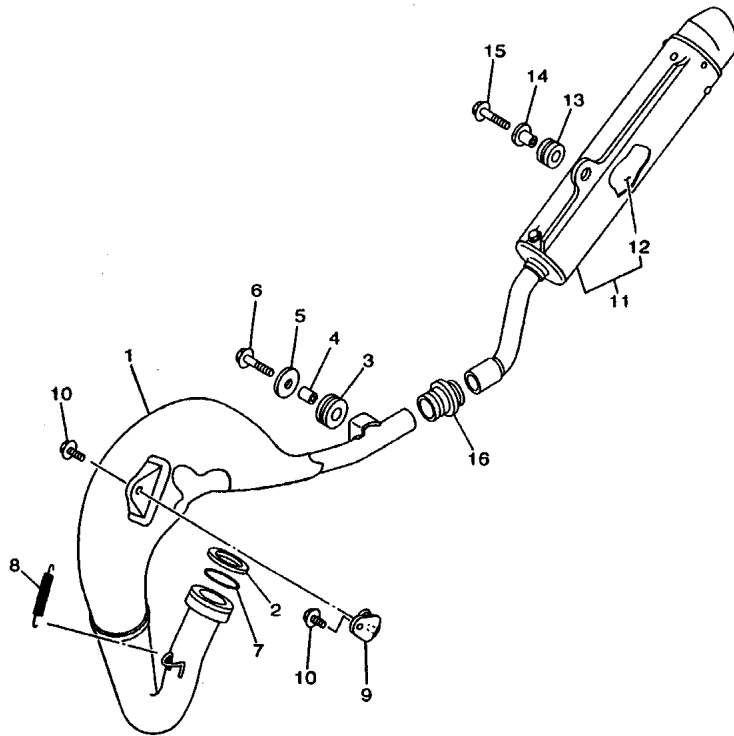

REF. NO.	PART NO.	DESCRIPTION	4ESA	4ESC	4LCB	4LCA	REMARKS
1	4ES-14610-10	EXHAUST PIPE ASSY 1	1	1	1	1	
2	90201-33299	WASHER, PLATE	1	1	1	1	
3	90480-18411	GROMMET	1	1	1	1	
4	90387-105L0	COLLAR	1	1	1	1	
5	90201-060A3	WASHER, PLATE	1	1	1	1	
6	95027-06025	BOLT, FLANGE	1	1	1	1	
7	93210-371A9	O-RING	1	1	1	1	
8	90507-20030	SPRING, TENSION	1	1	1	1	
9	565-14771-00	STAY, MUFFLER 1	1	1	1	1	
10	95027-06012	BOLT, FLANGE	2	2	2	2	
11	4ES-14753-10	SILENCER, EXHAUST	1	1	1	1	
12	4ES-1469A-00	.FIBER	1	1	1	1	
13	90480-16561	GROMMET	1	1	1	1	
14	90387-063G3	COLLAR	1	1	1	1	
15	95027-06025	BOLT, FLANGE	1	1	1	1	
16	17W-14615-00	JOINT, EXHAUST 1	1	1	1	1	

4ESA100-1070

FIG. 8 CRANKCASE

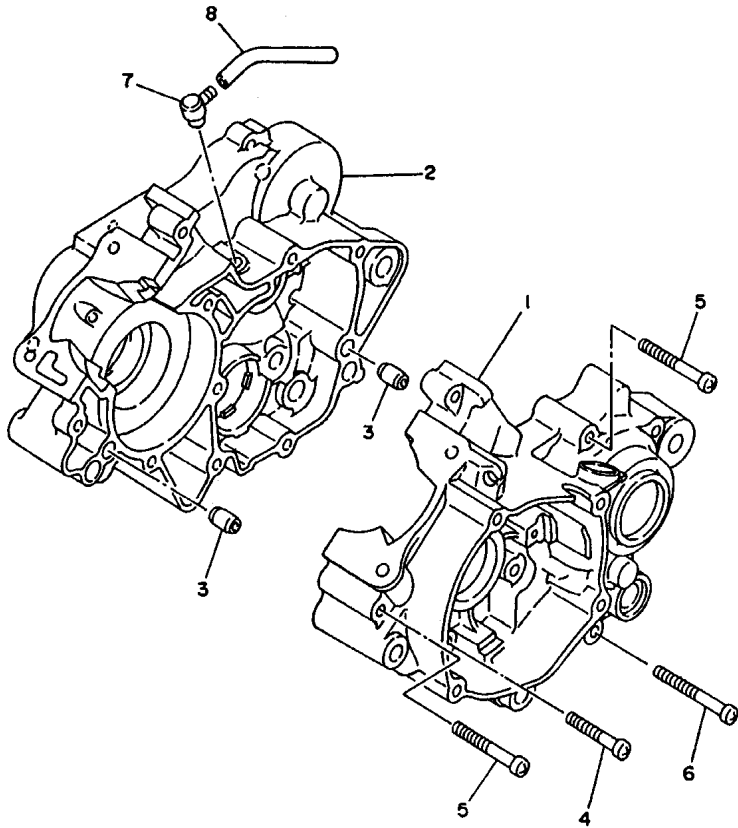

REF. NO.	PART NO.	DESCRIPTION	4ESA	4ESC	4LC8	4LCA	REMARKS
1	4ES-15111-00	CRANKCASE 1	1	1	1	1	
2	4ES-15121-02	CRANKCASE 2	1	1	1	1	
3	99530-10014	PIN, DOWEL	2	2	2	2	
4	98507-06040	SCREW, PAN HEAD	3	3	3	3	
5	98507-06050	SCREW, PAN HEAD	5	5	5	5	
6	98507-06060	SCREW, PAN HEAD	3	3	3	3	
7	120-15371-00	BREATHER	1	1	1	1	
8	90446-07349	HOSE	1	1	1	1	



4ES1100-3080

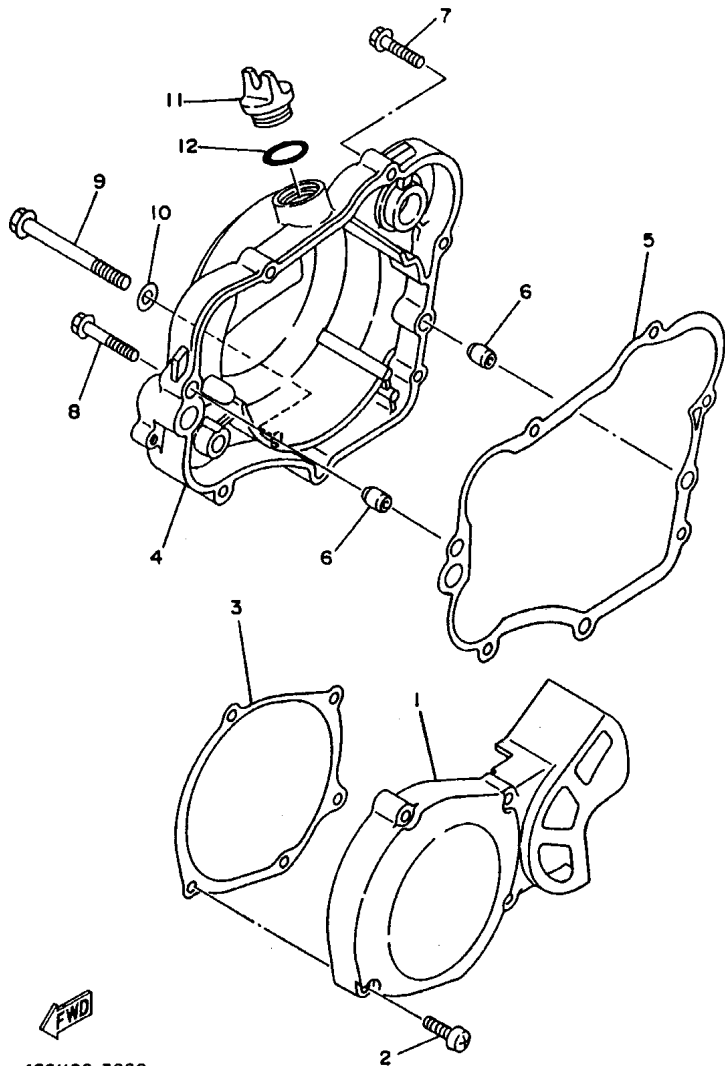

4ES1100-3090

FIG. 9 CRANKCASE COVER 1

REF. NO.	PART NO.	DESCRIPTION	4ESA	4ESC	4LCB	4LCA	REMARKS
1	4ES-15411-00	COVER, CRANKCASE 1	1	1	1	1	
2	98507-06030	SCREW, PAN HEAD	4	4	4	4	
3	4ES-15451-00	GASKET, CRANKCASE COVER 1	1	1	1	1	
4	4ES-15421-01	COVER, CRANKCASE 2	1	1	1	1	
5	4ES-15461-00	GASKET, CRANKCASE COVER 2	1	1	1	1	
6	99530-10014	PIN, DOWEL	2	2	2	2	
7	95027-06030	BOLT, FLANGE	4	4	4	4	
8	95027-06040	BOLT, FLANGE	1	1	1	1	
9	95027-08080	BOLT, FLANGE	1	1	1	1	
10	90430-08119	GASKET	1	1	1	1	
11	3Y1-15363-00	PLUG, OIL	1	1	1	1	
12	93210-19123	O-RING	1	1	1	1	

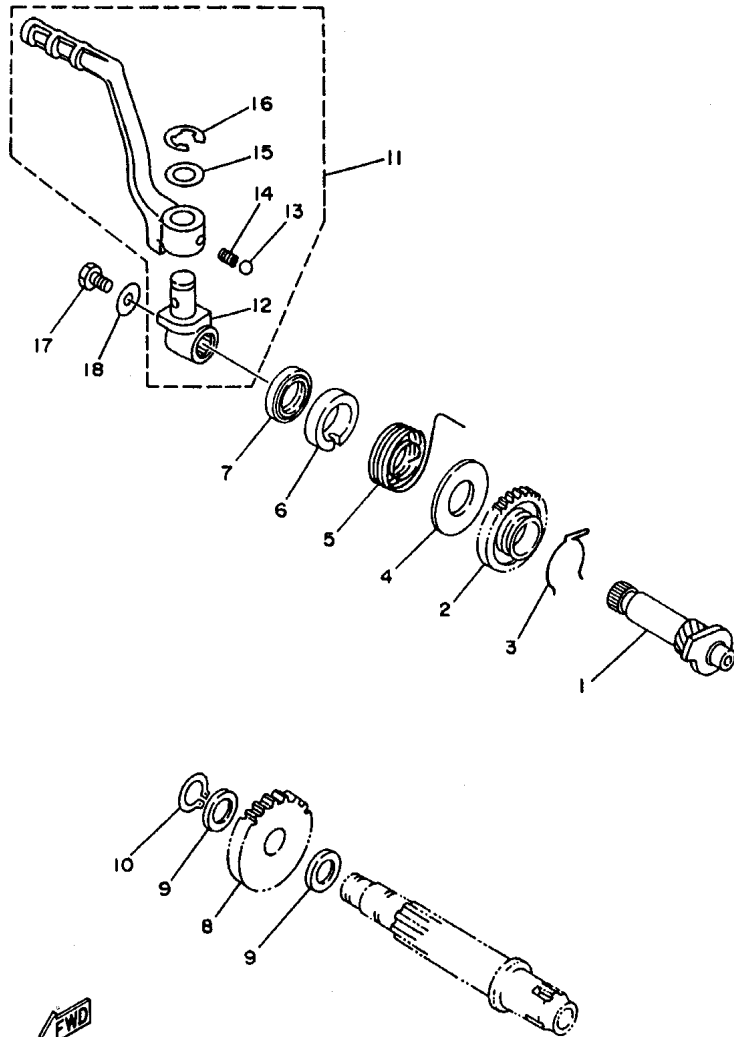

FIG. 10 STARTER

REF. NO.	PART NO.	DESCRIPTION	4ESA	4ESC	4LC8	4LCA	REMARKS
1	4ES-15660-00	KICK AXLE ASSY	1	1	1	1	
2	4ES-15641-00	GEAR, KICK	1	1	1	1	
3	90468-23194	CLIP	1	1	1	1	
4	90201-176L4	WASHER, PLATE	1	1	1	1	
5	90508-26750	SPRING, TORSION	1	1	1	1	
6	4ES-15664-00	GUIDE, SPRING	1	1	1	1	
7	93102-17263	OIL SEAL	1	1	1	1	
8	4ES-15651-00	GEAR, KICK IDLE	1	1	1	1	
9	90201-124F8	WASHER, PLATE	2	2	2	2	
10	99009-12400	CIRCLIP	1	1	1	1	
11	4ES-15620-00	KICK CRANK ASSY	1	1	1	1	
12	4ES-15621-00	.BOSS, KICK CRANK	1	1	1	1	
13	93507-32009	.BALL	1	1	1	1	
14	90501-12081	.SPRING, COMPRESSION	1	1	1	1	
15	90201-12631	.WASHER, PLATE	1	1	1	1	
16	93430-08007	.CIRCLIP	1	1	1	1	
17	95027-06012	BOLT, FLANGE	1	1	1	1	
18	90201-06060	WASHER, PLATE	1	1	1	1	

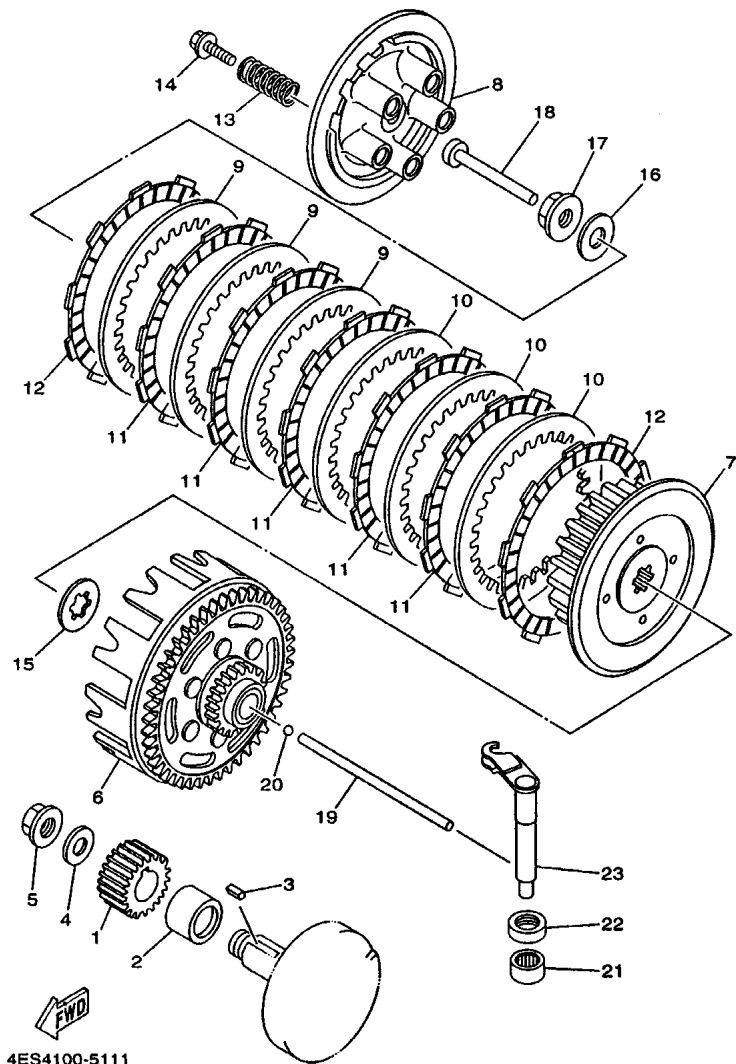
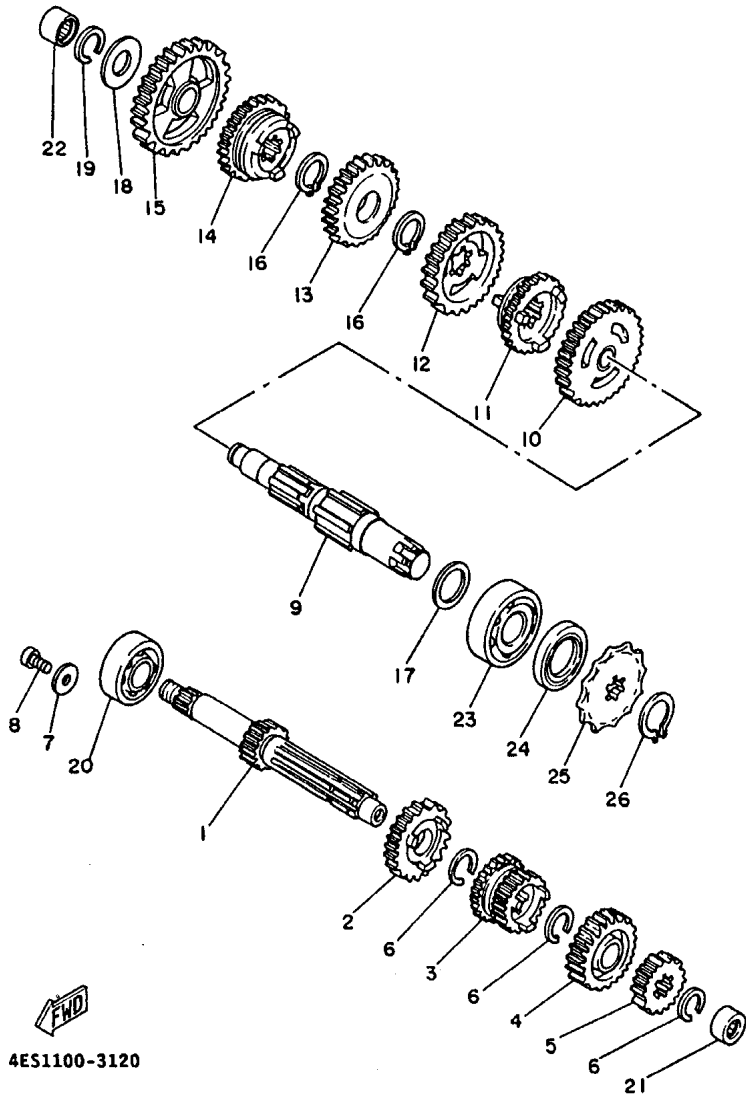

FIG. 11 CLUTCH

REF. NO.	PART NO.	DESCRIPTION	4ESA	4ESC	4LCB	4LCA	REMARKS
1	4ES-16111-00	GEAR, PRIMARY DRIVE	1	1	1	1	
2	90387-20488	COLLAR	1	1	1	1	
3	90282-05001	KEY, STRAIGHT (5MMX16MM)	1	1	1	1	
4	90208-12015	WASHER, CONICAL SPRING	1	1	1	1	
5	90179-12659	NUT	1	1	1	1	
6	4ES-16150-11	PRIMARY DRIVEN GEAR COMP.	1	1	1	1	
7	37F-16371-01	BOSS, CLUTCH	1	1	1	1	
8	2TK-16351-00	PLATE, PRESSURE 1	1	1	1	1	
9	257-16324-00	PLATE, CLUTCH 1	3	3	3	3	
10	131-16324-00	PLATE, CLUTCH 1	3	3	3	3	
11	4ES-16321-00	PLATE, FRICTION	5	5	5	5	
12	21V-16321-00	PLATE, FRICTION	2	2	2	2	
13	90501-20735	SPRING, COMPRESSION	5	5	5	5	
14	90119-05001	BOLT, WITH WASHER	5	5	5	5	
15	4V0-16154-00	PLATE, THRUST 1	1	1	1	1	
16	90208-12015	WASHER, CONICAL SPRING	1	1	1	1	
17	90179-12659	NUT	1	1	1	1	
18	4ES-16356-00	ROD, PUSH 1	1	1	1	1	
19	2RA-16357-00	ROD, PUSH 2	1	1	1	1	
20	93503-16003	BALL	1	1	1	1	
21	93315-11206	BEARING	1	1	1	1	
22	93102-12224	OIL SEAL	1	1	1	1	
23	4ES-16381-00	PUSH LEVER COMP.	1	1	1	1	

FIG. 12 TRANSMISSION



4ES1100-3120

REF. NO.	PART NO.	DESCRIPTION	4ESA	4ESC	4LCB	4LCA	REMARKS
1	4ES-17411-01	AXLE, MAIN	1	1	1	1	
2	4ES-17151-00	GEAR, 5TH PINION	1	1	1	1	
3	4ES-17131-00	GEAR, 3RD PINION	1	1	1	1	
4	4ES-17161-00	GEAR, 6TH PINION	1	1	1	1	
5	4ES-17121-01	GEAR, 2ND PINION	1	1	1	1	
6	93440-17064	CIRCLIP	3	3	3	3	
7	90201-06060	WASHER, PLATE	2	2	2	2	
8	90157-06071	SCREW, PAN HEAD	2	2	2	2	
9	4ES-17421-00	AXLE, DRIVE	1	1	1	1	
10	4ES-17221-01	GEAR, 2ND WHEEL	1	1	1	1	
11	4ES-17261-01	GEAR, 6TH WHEEL	1	1	1	1	
12	4ES-17231-01	GEAR, 3RD WHEEL	1	1	1	1	
13	4ES-17241-00	GEAR, 4TH WHEEL	1	1	1	1	
14	4ES-17251-00	GEAR, 5TH WHEEL	1	1	1	1	
15	4ES-17211-01	GEAR, 1ST WHEEL	1	1	1	1	
16	93410-20038	CIRCLIP	2	2	2	2	
17	90201-203E7	WASHER, PLATE	1	1	1	1	
18	164-17427-00-06	SHIM 1 (0.6T)	1	1	1	1	UR
	164-17427-00-08	SHIM 1 (0.8T)	1	1	1	1	UR
	164-17427-00-10	SHIM 1 (1.0T)	1	1	1	1	UR
19	93440-15012	CIRCLIP	1	1	1	1	
20	93306-20333	BEARING	1	1	1	1	
21	93317-11245	BEARING	1	1	1	1	
22	93315-31502	BEARING	1	1	1	1	
23	93306-20401	BEARING (B6204)	1	1	1	1	
24	93102-20143	OIL SEAL	1	1	1	1	
25	93822-14037	SPROCKET,DRIVE 14T(1741746140)	1	1			STD

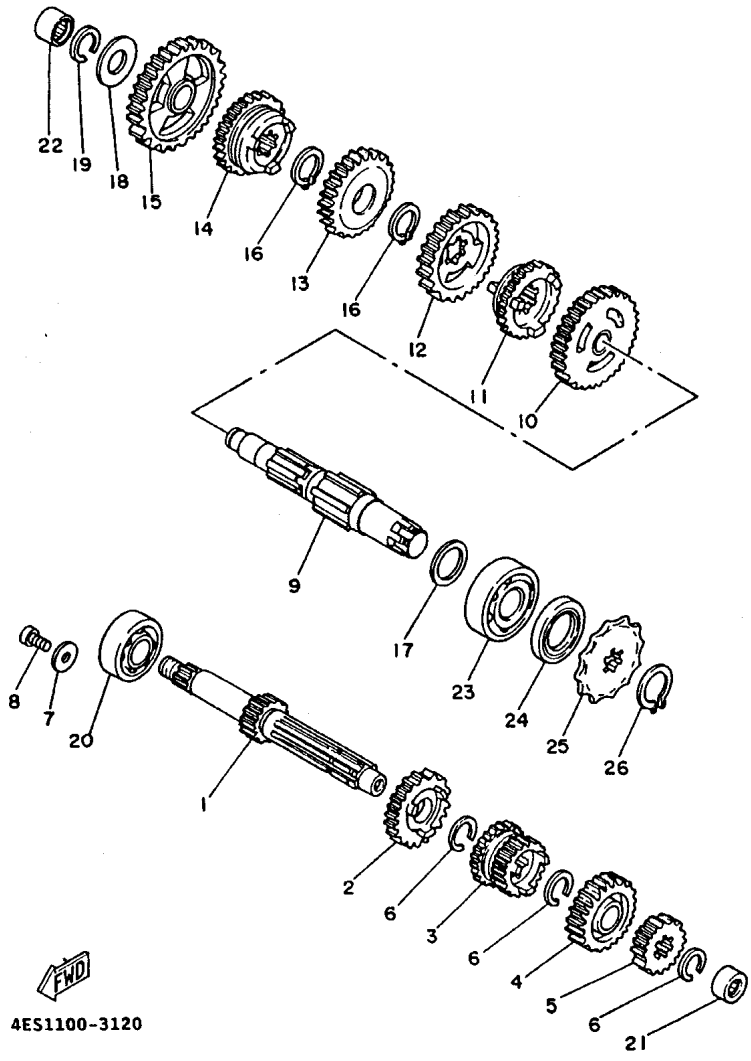

4ES1100-3120

FIG. 12 TRANSMISSION

REF. NO.	PART NO.	DESCRIPTION	4ESA	4ESC	4LC8	4LCA	REMARKS
25	93822-13024	SPROCKET,DRIVE 13T(1741746130)			1	1	STD
	93822-12012	SPROCKET,DRIVE 12T(1741746120)	1	1	1	1	AP
	93822-13024	SPROCKET,DRIVE 13T(1741746130)	1	1			AP
	93822-14037	SPROCKET,DRIVE 14T(1741746140)			1	1	AP
	93822-15065	SPROCKET,DRIVE 15T(1741746150)	1	1	1	1	AP
26	99009-18400	CIRCLIP	1	1	1	1	

FIG. 14 SHIFT SHAFT

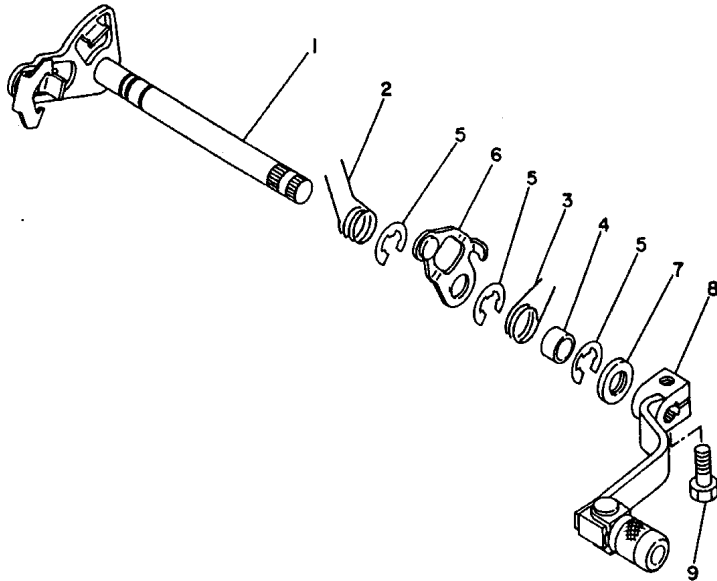

REF. NO.	PART NO.	DESCRIPTION	4ESA	4ESC	4LC8	4LCA	REMARKS
1	4ES-18101-00	SHIFT SHAFT ASSY	1	1	1	1	
2	90508-32553	SPRING, TORSION	1	1	1	1	
3	90508-242A6	SPRING, TORSION	1	1	1	1	
4	90387-126Y7	COLLAR	1	1	1	1	
5	99001-10600	CIRCLIP	3	3	3	3	
6	4BA-18140-00	STOPPER LEVER ASSY	1	1	1	1	
7	93101-12173	OIL SEAL	1	1	1	1	
8	2HF-18110-01	SHIFT PEDAL ASSY	1	1	1	1	
9	97027-06020	BOLT	1	1	1	1	



4ES1100-3140

FIG. 16 FENDER

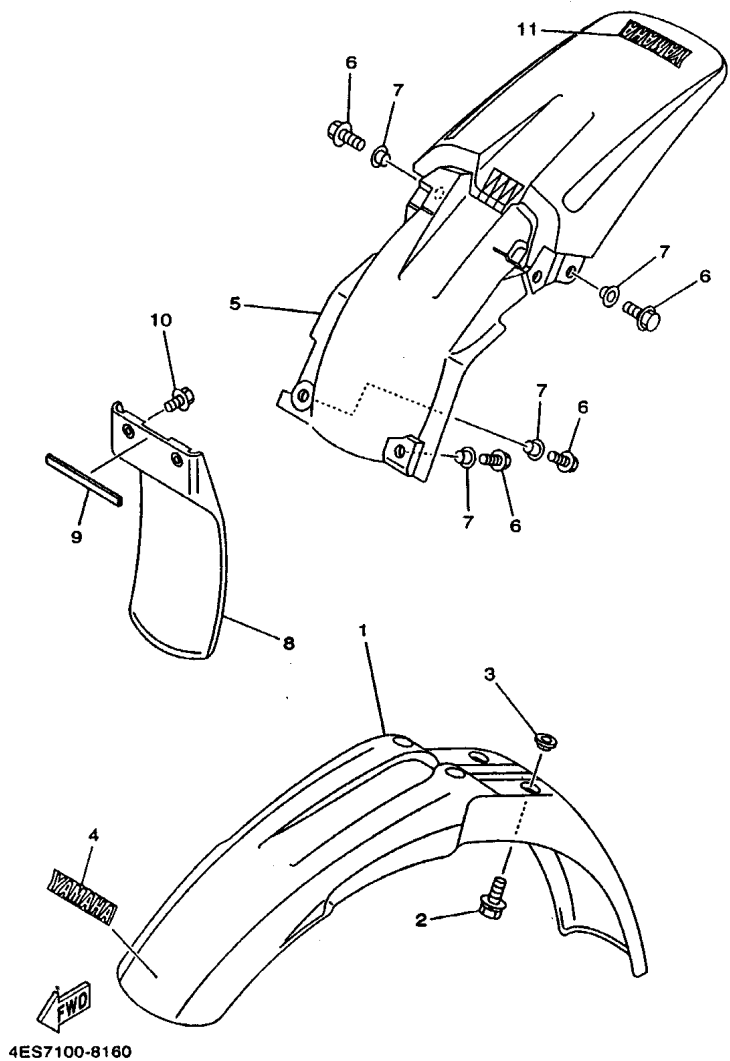

REF. NO.	PART NO.	DESCRIPTION	4ESA	4ESC	4LCB	4LCA	REMARKS
1	4ES-21511-20	FENDER, FRONT	1	1	1	1	
2	90119-06063	BOLT, WITH WASHER	4	4	4	4	
3	90209-06187	WASHER	4	4	4	4	
4	4ES-2153E-01	EMBLEM, YAMAHA	1	1	1	1	
5	4ES-21611-10	FENDER, REAR	1	1	1	1	
6	95027-06016	BOLT, FLANGE	4	4	4	4	
7	90387-064X4	COLLAR	4	4	4	4	
8	4ES-21642-00	GUARD, FLAP	1	1	1	1	
9	25G-21575-00	SEAL 1			1	1	
10	90119-06185	BOLT, WITH WASHER	2	2	2	2	
11	4ES-2153E-00	EMBLEM, YAMAHA	1	1	1	1	EXCEPT FOR CANADA

FIG. 17 SIDE COVER

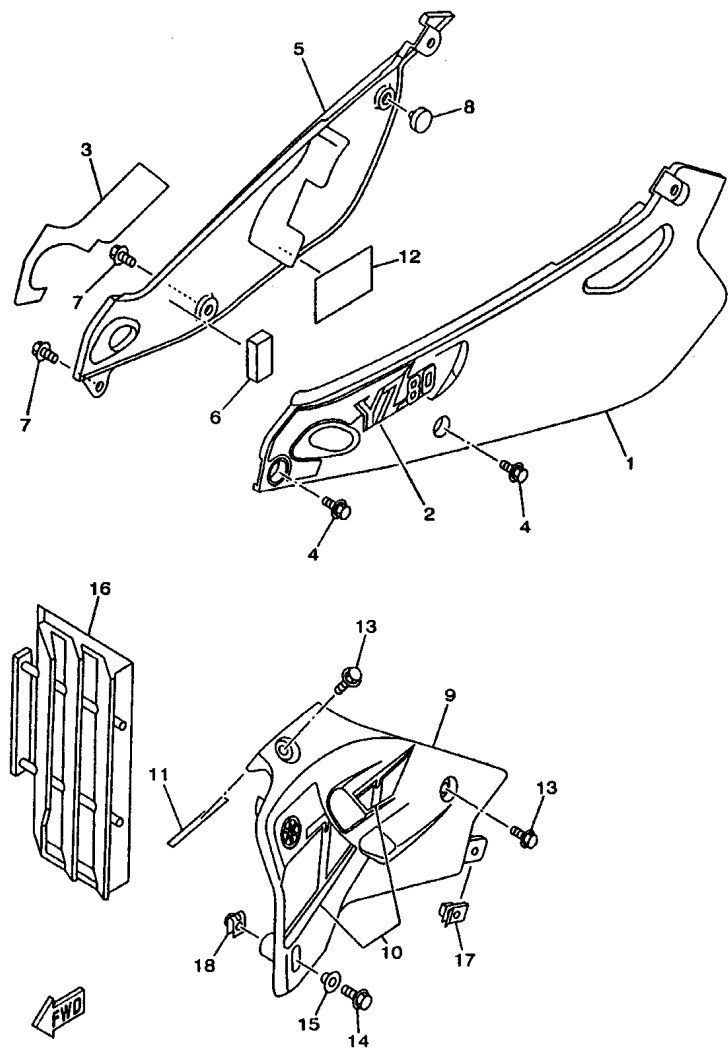

4ESA100-1170

REF. NO.	PART NO.	DESCRIPTION	4ESA	4ESC	4LCB	4LCA	REMARKS
1	4ES-21711-00	COVER, SIDE 1	1	1	1	1	
2	4ES-2173E-50	GRAPHIC 1	1	1	1	1	
3	4ES-2173F-50	GRAPHIC 2	1	1	1	1	
4	90119-06217	BOLT, WITH WASHER	2	2	2	2	
5	4ES-21721-00	COVER, SIDE 2	1	1	1	1	
6	4ES-21735-00	SEAL 2	1	1	1	1	
7	90119-06217	BOLT, WITH WASHER	2	2	2	2	
8	22W-24181-00	DAMPER, LOCATING 1	1	1	1	1	
9	4ES-21731-20	COVER, SIDE 3	1	1	1	1	
10	4ES-2173L-40	GRAPHIC SET 1	1	1	1	1	
11	4ES-21732-00	SEAL 1	1	1	1	1	
12	4DJ-2174A-00	INSULATOR, SIDE COVER	1	1	1	1	
13	90109-067F4	BOLT	2	2	2	2	
14	95027-06016	BOLT, FLANGE	1	1	1	1	
15	90387-062M9	COLLAR	1	1	1	1	
16	4EW-2172A-00	PANEL 1	1	1	1	1	
17	90183-06023	NUT, SPRING	1	1	1	1	
18	90183-06069	NUT, SPRING	1	1	1	1	

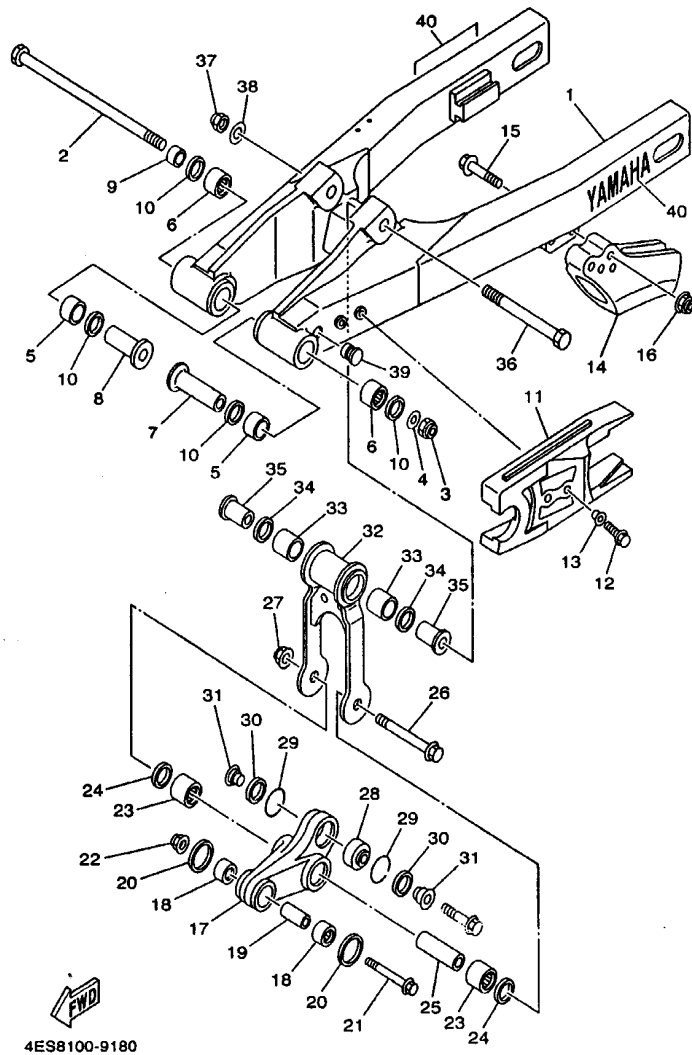
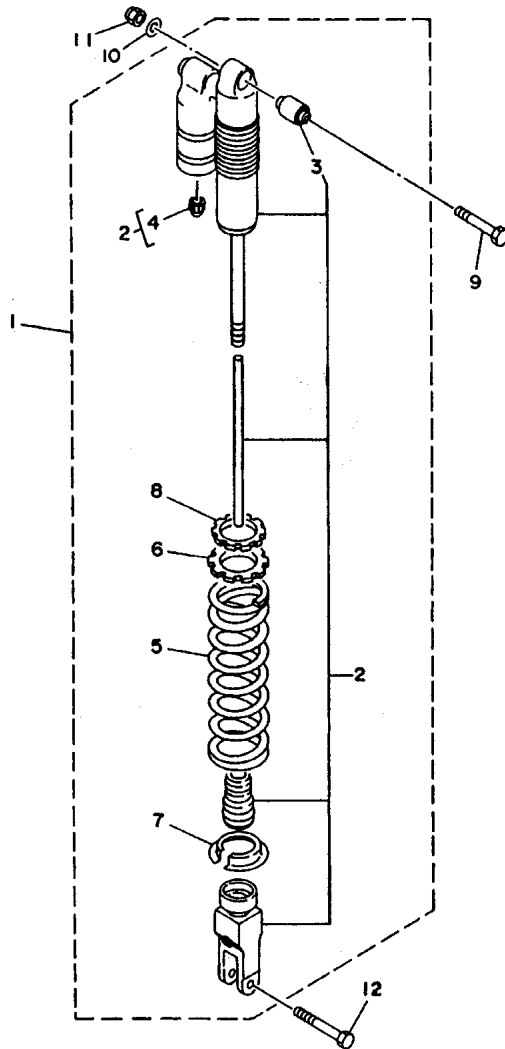

FIG. 18 REAR ARM

REF. NO.	PART NO.	DESCRIPTION	4ESA	4ESC	4LCB	4LCA	REMARKS
1	4ES-22110-01	REAR ARM COMP.	1	1			
	4LB-22110-01	REAR ARM COMP.			1	1	
2	22W-25181-01	AXLE, WHEEL	1	1	1	1	
3	95617-12100	NUT, U	1	1	1	1	
4	90201-124G9	WASHER, PLATE	1	1	1	1	
5	90385-17042	BUSH	2	2	2	2	
6	93317-21746	BEARING	2	2	2	2	
7	90387-127J8	COLLAR	1	1	1	1	
8	90387-127J7	COLLAR	1	1	1	1	
9	90387-1200U	COLLAR	1	1	1	1	
10	93109-17071	OIL SEAL	4	4	4	4	
11	4ES-22151-10	SEAL, GUARD	1	1	1	1	
12	95027-06014	BOLT, FLANGE	2	2	2	2	
13	90387-062X0	COLLAR	2	2	2	2	
14	39K-22199-00	SUPPORT, CHAIN	1	1	1	1	
15	90105-08310	BOLT, WASHER BASED	2	2	2	2	
16	95607-08200	NUT, SELF-LOCKING	2	2	2	2	
17	4ES-2217A-00	ARM, RELAY	1	1	1	1	
18	93315-21455	BEARING	2	2	2	2	
19	90380-10218	BUSH, SOLID	1	1	1	1	
20	4ES-22129-00	COVER, THRUST 2	2	2	2	2	
21	90105-10582	BOLT, WASHER BASED	1	1	1	1	
22	95607-10200	NUT, SELF-LOCKING	1	1	1	1	
23	93317-31771	BEARING	2	2	2	2	
24	93101-17062	OIL SEAL	2	2	2	2	
25	90380-12219	BUSH, SOLID	1	1	1	1	
26	90105-12382	BOLT, WASHER BASED	1	1	1	1	

FIG. 19 REAR SUSPENSION



4ES1100-3190

REF. NO.	PART NO.	DESCRIPTION	4ESA	4ESC	4LCB	4LCA	REMARKS
1	4ES-22210-C0	SHOCK ABSORBER ASSY, REAR	1				FOR USA
	4ES-22210-D0	SHOCK ABSORBER ASSY, REAR	1				FOR CAN
	4ES-22210-E0	SHOCK ABSORBER ASSY, REAR	1				FOR ZAF
	4ES-22210-F0	SHOCK ABSORBER ASSY, REAR	1				FOR EUR
	4GT-22210-40	SHOCK ABSORBER ASSY, REAR		1			
	4LB-22210-70	SHOCK ABSORBER ASSY, REAR				1	
	4LB-22210-80	SHOCK ABSORBER ASSY, REAR			1		
2	4ES-22201-30	.DAMPER SUB ASSY	1				FOR USA
	4ES-22201-40	.DAMPER SUB ASSY	1				FOR CAN
	4ES-22201-50	.DAMPER SUB ASSY	1				FOR ZAF
	4ES-22201-60	.DAMPER SUB ASSY	1				FOR EUR
	4GT-22201-10	.DAMPER SUB ASSY		1			
	4LB-22201-50	.DAMPER SUB ASSY				1	
	4LB-22201-60	.DAMPER SUB ASSY			1		
3	4ES-22216-00	.BUSH, REAR SHOCK ABSORBER	1	1	1	1	
4	58T-23184-L0	.CAP, AIR VALVE	1	1	1	1	
5	4ES-22212-F0	.SPRING (K=5.0)	1	1			
	4ES-22212-K0	.SPRING (K=4.6)	1				FOR EUR
	4ES-22212-G0	.SPRING (K=4.8)			1		
	4ES-22212-H0	.SPRING (K=5.2)				1	
6	4ES-22214-00	.GUIDE, SPRING 1	1	1	1	1	
7	3JD-22214-00	.GUIDE, SPRING 1	1	1	1	1	
8	4ES-22251-00	.NUT 1	1	1	1	1	
9	90109-10729	BOLT	1	1	1	1	
10	92907-10600	WASHER, PLATE	1	1	1	1	
11	90185-10110	NUT, SELF-LOCKING	1	1	1	1	
12	90105-10614	BOLT, WASHER BASED	1	1	1	1	

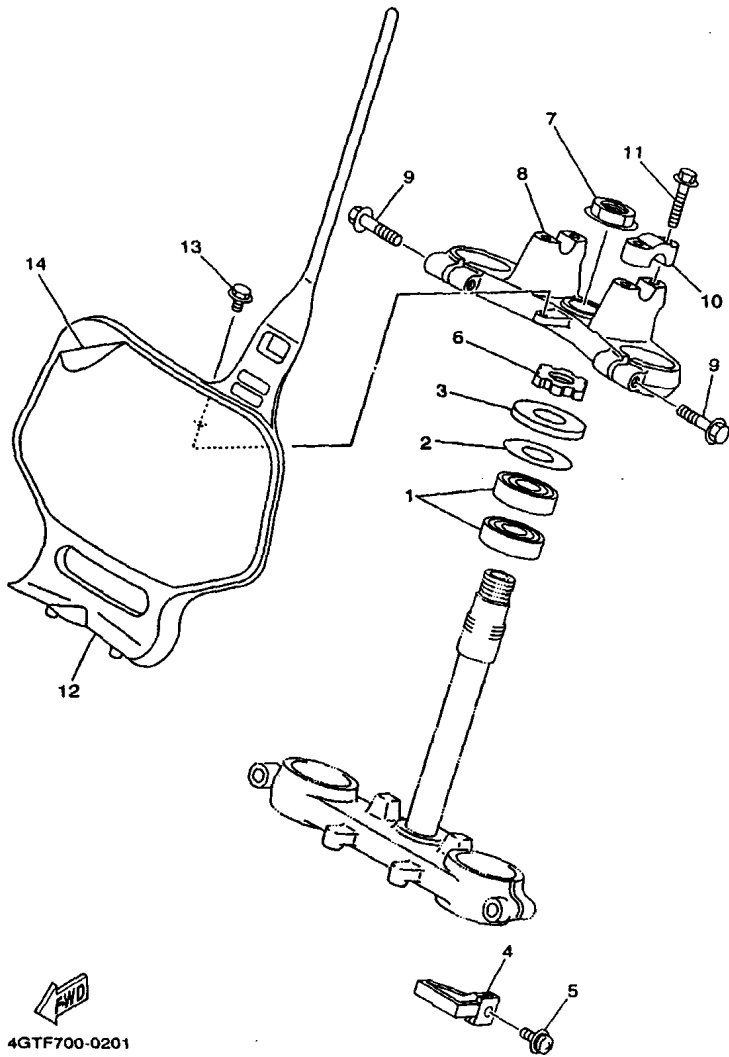

4GTF700-0201

FIG. 20 STEERING

REF. NO.	PART NO.	DESCRIPTION	4ESA	4ESC	4LCB	4LCA	REMARKS
1	93332-00079	BEARING	2	2	2	2	
2	90201-256K5	WASHER, PLATE (0.5T)	1	1	1	1	
3	1J7-23415-00	COVER, BALL RACE 1	1	1	1	1	
4	4DA-23389-00	GUIDE, CABLE	1	1	1	1	
5	90157-05079	SCREW, PAN HEAD	1	1	1	1	
6	90179-25033	NUT	1	1	1	1	
7	90179-22412	NUT	1	1	1	1	
8	4ES-23435-00	CROWN, HANDLE	1	1	1	1	
9	95807-08035	BOLT, FLANGE	2	2	2	2	
10	3SP-23441-00	HOLDER, HANDLE UPPER	2	2	2	2	
11	95027-08030	BOLT, FLANGE	4	4	4	4	
12	4ES-23485-20	PLATE, NUMBER	1	1	1	1	
13	95027-06012	BOLT, FLANGE	1	1	1	1	
14	4ES-2339E-00	GRAPHIC 1	1	1	1	1	

C10

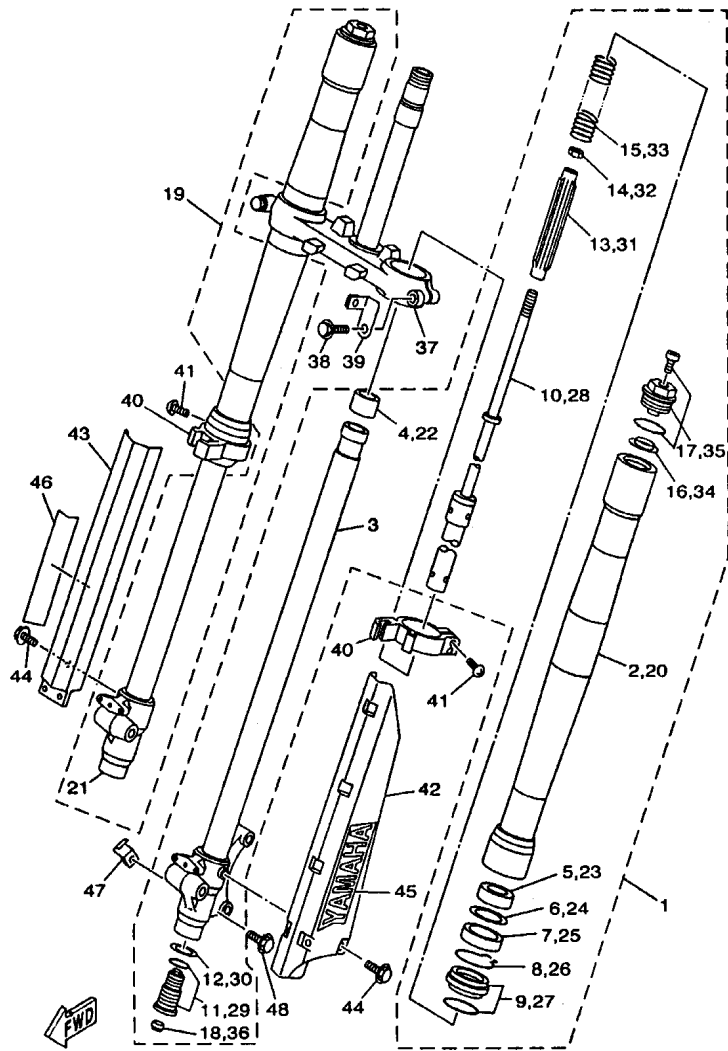

4ESA100-1210

FIG. 21 FRONT FORK

REF. NO.	PART NO.	DESCRIPTION	4ESA	4ESC	4LCB	4LCA	REMARKS
1	4ES-23102-20	FRONT FORK ASSY (L.H)	1	1			
	4LB-23102-20	FRONT FORK ASSY (L.H)			1	1	
2	4ES-23136-20	.TUBE, OUTER (RIGHT)	1	1	1	1	
3	4ES-23120-00	.INNER TUBE COMP.2	1	1	1	1	
4	4ES-23171-00	.PISTON, FRONT FORK	1	1	1	1	
5	4ES-23125-00	.METAL, SLIDE 1	1	1	1	1	
6	5K5-23149-00	.WASHER, SPRING UPPER	1	1	1	1	
7	4ES-23145-00	.OIL SEAL	1	1	1	1	
8	4A1-23156-00	.CLIP, OIL SEAL	1	1	1	1	
9	4ES-23144-00	.SEAL, DUST	1	1	1	1	
10	4ES-23170-10	.CYLINDER COMP., FRONT FORK	1	1	1	1	
11	4ES-2316A-10	.VALVE COMP.	1	1			
	4LB-2316A-20	.VALVE COMP.			1	1	
12	2HH-23158-L0	.GASKET	1	1	1	1	
13	4ES-23142-00	.SEAT, SPRING UPPER	1	1	1	1	
14	3XJ-23357-L0	.NUT	1	1	1	1	
15	4ES-23141-40	.SPRING, FRONT FORK (K=0.29)	1	1			
	4LB-23141-10	.SPRING, FRONT FORK (K=0.30)			1	1	
16	3GM-23142-00	.SEAT, SPRING UPPER	1	1	1	1	
17	4ES-23111-10	.BOLT, CAP	1	1	1	1	
18	3JD-2312G-L0	.PLUG	1	1	1	1	
19	4ES-23103-20	FRONT FORK ASSY (R.H)	1	1			
	4LB-23103-20	FRONT FORK ASSY (R.H)			1	1	
20	4ES-23136-20	.TUBE, OUTER (RIGHT)	1	1	1	1	
21	4ES-23110-00	.INNER TUBE COMP.1	1	1	1	1	
22	4ES-23171-00	.PISTON, FRONT FORK	1	1	1	1	
23	4ES-23125-00	.METAL, SLIDE 1	1	1	1	1	

FIG. 21 FRONT FORK

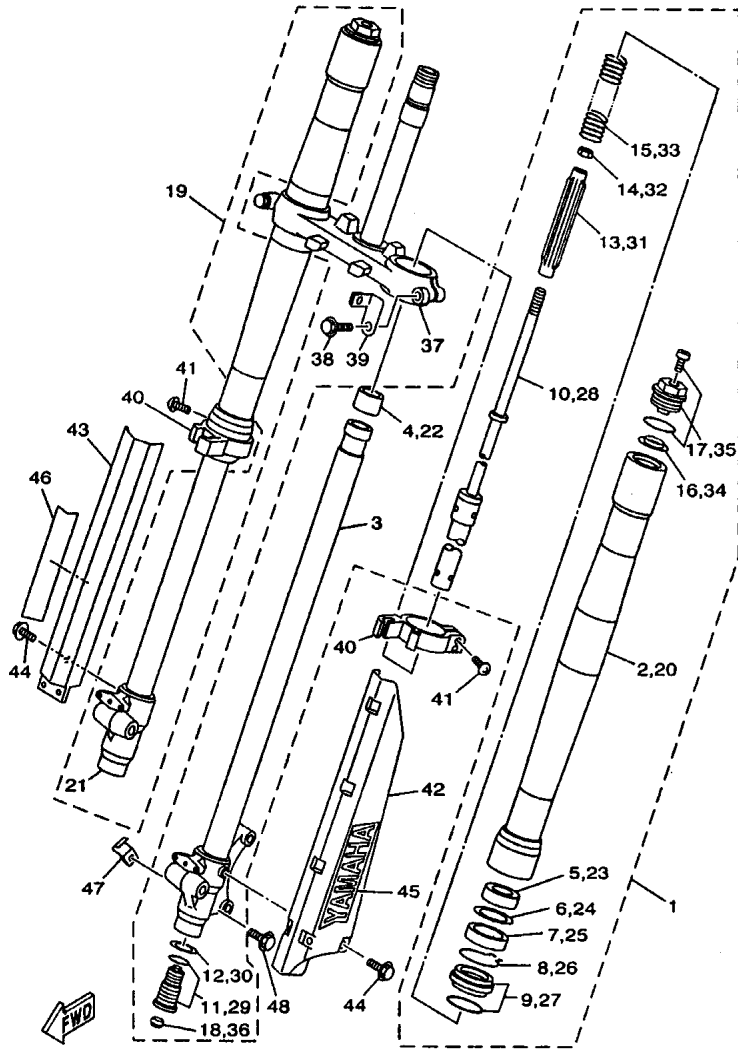

4ESA100-1210

REF. NO.	PART NO.	DESCRIPTION	4ESA	4ESC	4LC8	4LCA	REMARKS
24	5K5-23149-00	.WASHER, SPRING UPPER	1	1	1	1	
25	4ES-23145-00	.OIL SEAL	1	1	1	1	
26	4A1-23156-00	.CLIP, OIL SEAL	1	1	1	1	
27	4ES-23144-00	.SEAL, DUST	1	1	1	1	
28	4ES-23170-10	.CYLINDER COMP., FRONT FORK	1	1	1	1	
29	4ES-2316A-10	.VALVE COMP.	1	1			
	4LB-2316A-20	.VALVE COMP.			1	1	
30	2HH-23158-L0	.GASKET	1	1	1	1	
31	4ES-23142-00	.SEAT, SPRING UPPER	1	1	1	1	
32	3XJ-23357-L0	.NUT	1	1	1	1	
33	4ES-23141-40	.SPRING, FRONT FORK (K=0.29)	1	1			
	4LB-23141-10	.SPRING, FRONT FORK (K=0.30)			1	1	
34	3GM-23142-00	.SEAT, SPRING UPPER	1	1	1	1	
35	4ES-23111-10	.BOLT, CAP	1	1	1	1	
36	3JD-2312G-L0	.PLUG	1	1	1	1	
37	4ES-23340-00	UNDER BRACKET COMP.	1	1	1	1	
38	95021-10040	BOLT, FLANGE	2	2	2	2	
39	4ES-2331E-00	GUIDE, CABLE	1	1	1	1	
40	4ES-2314F-00	PROTECTOR GUIDE COMP., 1	2	2	2	2	
41	4V4-23194-L0	SCREW, BOOT BAND	4	4	4	4	
42	4ES-2314H-L1	PROTECTOR COMP., 1	1	1	1	1	
43	4ES-2314J-L0	PROTECTOR COMP., 2	1	1	1	1	
44	95024-06010	BOLT, FLANGE	6	6	6	6	
45	4XL-2153A-10	EMBLEM, YAMAHA	1	1	1	1	
46	4XL-2153A-10	EMBLEM, YAMAHA	1	1	1	1	
47	4ES-23318-00	HOLDER, CABLE 1	1	1	1	1	
48	95027-06016	BOLT, FLANGE	1	1	1	1	

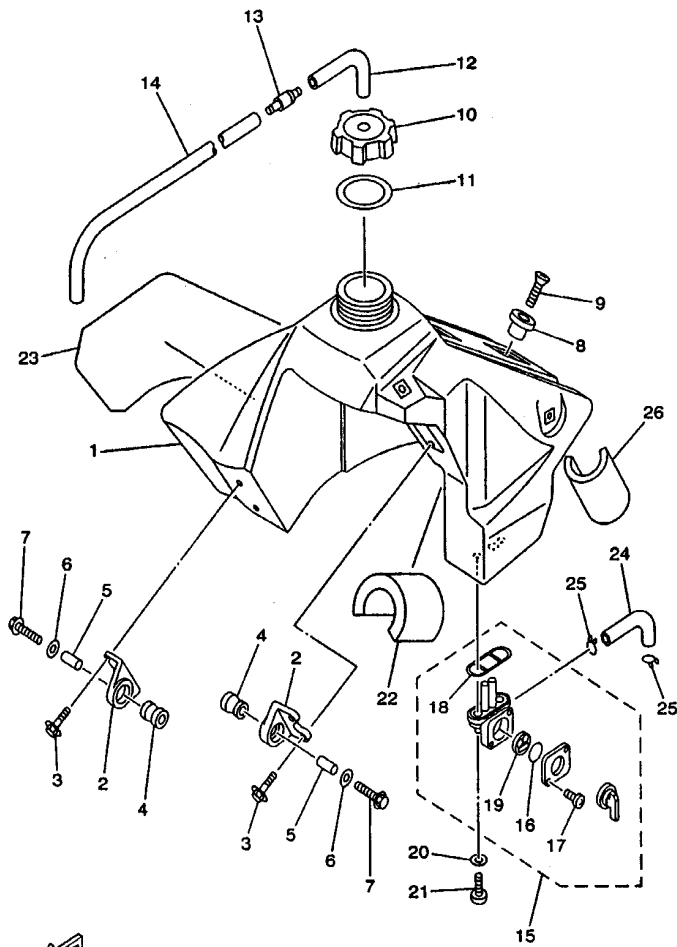

4ES7100-8220

FIG. 22 FUEL TANK

REF. NO.	PART NO.	DESCRIPTION	4ESA	4ESC	4LCB	4LCA	REMARKS
			1	1	1	1	
1	4ES-24110-20	FUEL TANK COMP.	1	1	1	1	
2	24X-24144-00	HOLDER, DAMPER	2	2	2	2	
3	95027-06016	BOLT, FLANGE	4	4	4	4	
4	90480-18549	GROMMET	2	2	2	2	
5	90387-06027	COLLAR	2	2	2	2	
6	90201-06071	WASHER, PLATE	2	2	2	2	
7	95027-06030	BOLT, FLANGE	2	2	2	2	
8	4EW-2412F-00	BRACKET, SEAT	1	1	1	1	
9	98707-06025	SCREW, FLAT HEAD	1	1	1	1	
10	5X7-24611-01	BODY, CAP	1	1	1	1	
11	5X7-24612-00	GASKET, CAP	1	1	1	1	
12	90445-09220	HOSE	1	1	1	1	
13	3XJ-24380-00	PIPE JOINT ASSY	1	1	1	1	
14	90445-09100	HOSE	1	1	1	1	
15	4DP-24500-00	FUEL COCK ASSY 1	1	1	1	1	
16	3AJ-24534-00	.SEAL, COCK	1	1	1	1	
17	97801-03008	.SCREW, PAN HEAD	2	2	2	2	
18	4X8-24512-00	.O-RING	1	1	1	1	
19	3AJ-24523-00	.VALVE PACKING	1	1	1	1	
20	90202-05193	WASHER, PLATE	2	2	2	2	
21	90149-06011	SCREW	2	2	2	2	
22	3Y0-24183-00	DAMPER, LOCATING 3	1	1	1	1	
23	4ES-24244-10	GRAPHIC, FUEL TANK 1	1	1	1	1	
24	4ES-24311-10	PIPE, FUEL 1	1	1	1	1	
25	90467-10008	CLIP	2	2	2	2	
26	5TL-28371-00	DAMPER	1	1	1	1	

FIG. 23 SEAT

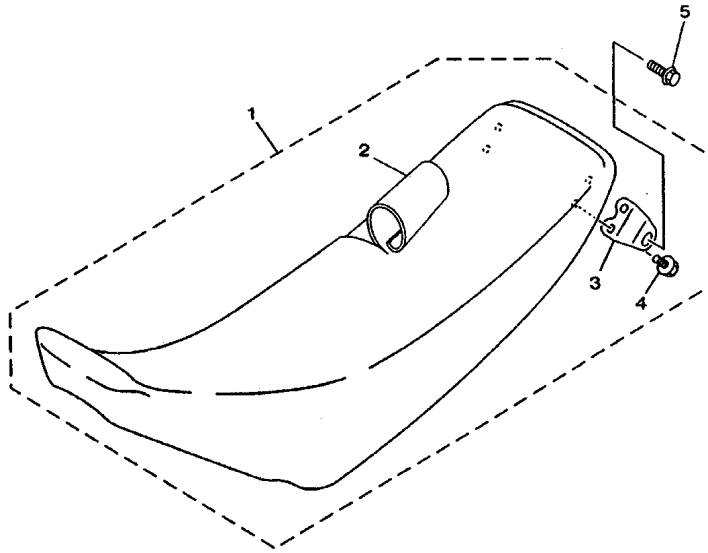

REF. NO.	PART NO.	DESCRIPTION	4ESA	4ESC	4LCB	4LCA	REMARKS
1	4ES-24770-50	SEMI-DOUBLE SEAT ASSY	1	1	1	1	
2	4ES-24731-50	.COVER, SEAT	1	1	1	1	
3	4ES-24728-00	.BRACKET, SEAT	2	2	2	2	
4	95027-06012	.BOLT, FLANGE	4	4	4	4	
5	90119-06225	BOLT, WITH WASHER	2	2	2	2	

 4ES8100-9230

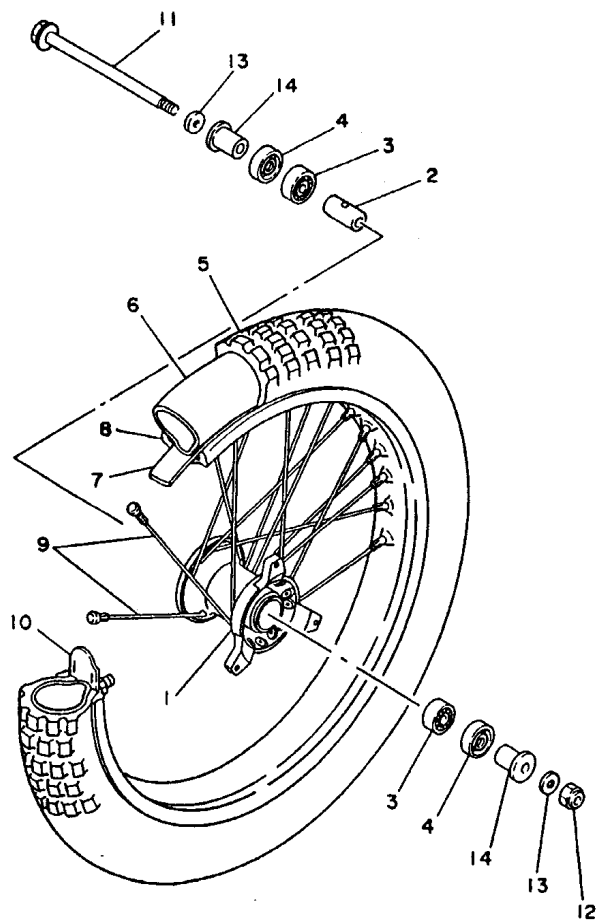



4ES1100-3240

FIG. 24 FRONT WHEEL

REF. NO.	PART NO.	DESCRIPTION	MESA	MESC	ALCB	ALCA	REMARKS
1	4ES-25111-00	HUB, FRONT	1	1	1	1	
2	90387-124H0	COLLAR	1	1	1	1	
3	93306-20120	BEARING	2	2	2	2	
4	93106-20031	OIL SEAL	2	2	2	2	
5	94107-1706B	TIRE (70/100-17 40M D752F)	1				DUNLOP
	94107-177Y5	TIRE (70/100-17 40M K490)	1	1			DUNLOP EXCEPT FOR CAN DUNLOP
	94107-1906D	TIRE (70/100-19 42M D752F)			1		
	94107-1902L	TIRE (70/100-19 42M K490)				1	DUNLOP
6	94207-17284	TUBE (70/100-17 TR4)	1	1			DUNLOP
	94207-19290	TUBE (70/100-19 TR-4)			1	1	DUNLOP
7	94307-17166	BAND, RIM (80/90,70/100-17)	1	1			DUNLOP
	94307-19170	BAND, RIM (70/100-19)			1	1	DUNLOP
8	94414-17530	RIM (1.40-17)	1	1			
	94414-19521	RIM (1.40-19)			1	1	
9	4ES-25104-20	SPOKE SET, FRONT	1	1			
	4LB-25104-00	SPOKE SET, FRONT			1	1	
10	1T1-25194-00	SPACER, BEAD	1	1	1	1	
11	4ES-25181-00	AXLE, WHEEL	1	1	1	1	
12	90185-12046	NUT, SELF-LOCKING	1	1	1	1	
13	90201-12362	WASHER, PLATE	2	2	2	2	
14	4ES-25183-10	COLLAR, WHEEL	2	2	2	2	

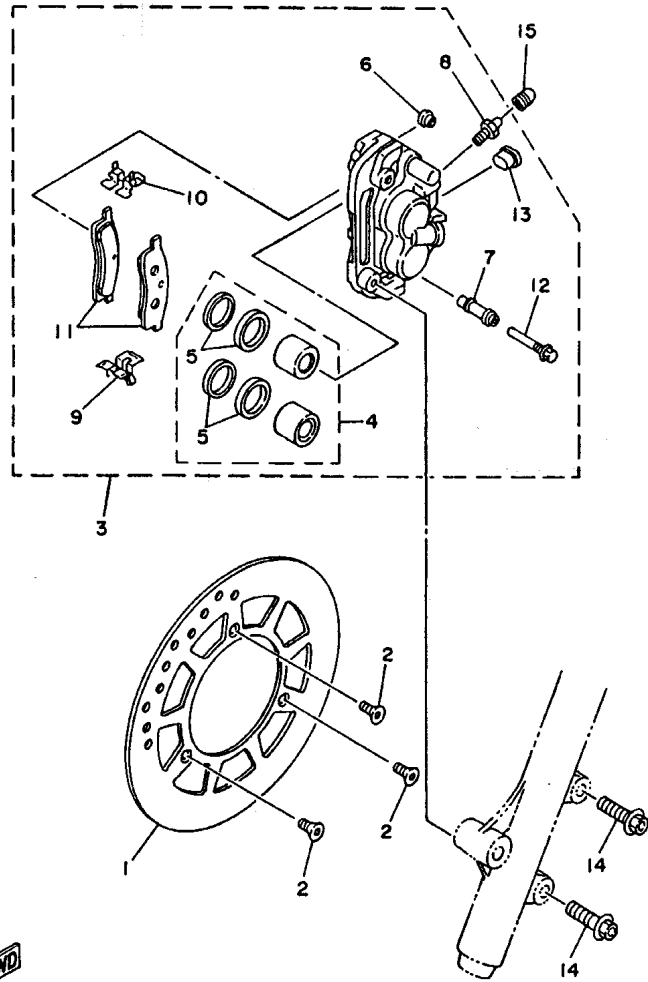
FIG. 25 FRONT BRAKE CALIPER



4ES3100-4250

REF. NO.	PART NO.	DESCRIPTION	4ESA	4ESC	4LC8	4LCA	REMARKS
1	4ES-2582T-00	DISC, BRAKE	1	1	1	1	
2	90149-06327	SCREW	3	3	3	3	
3	4ES-2580T-20	CALIPER ASSY (LEFT)	1	1	1	1	
4	4ES-W0057-10	.PISTON ASSY, CALIPER	1	1	1	1	
5	4ES-W0047-10	..CALIPER SEAL KIT	1	1	1	1	
6	5R2-25937-00	.BOOT 2	1	1	1	1	
7	56A-25937-00	.BOOT 2	1	1	1	1	
8	47X-25824-00	.SCREW, BLEED	1	1	1	1	
9	56A-25919-00	.SUPPORT, PAD	1	1	1	1	
10	56A-25919-10	.SUPPORT, PAD	1	1	1	1	
11	4ES-W0045-20	.BRAKE PAD KIT	1	1	1	1	
12	56A-25926-00	.BOLT	1	1	1	1	
13	34X-25845-00	.CAP, INDICATOR	1	1	1	1	
14	90105-08211	BOLT, WASHER BASED	2	2	2	2	
15	51L-25825-00	CAP	1	1	1	1	

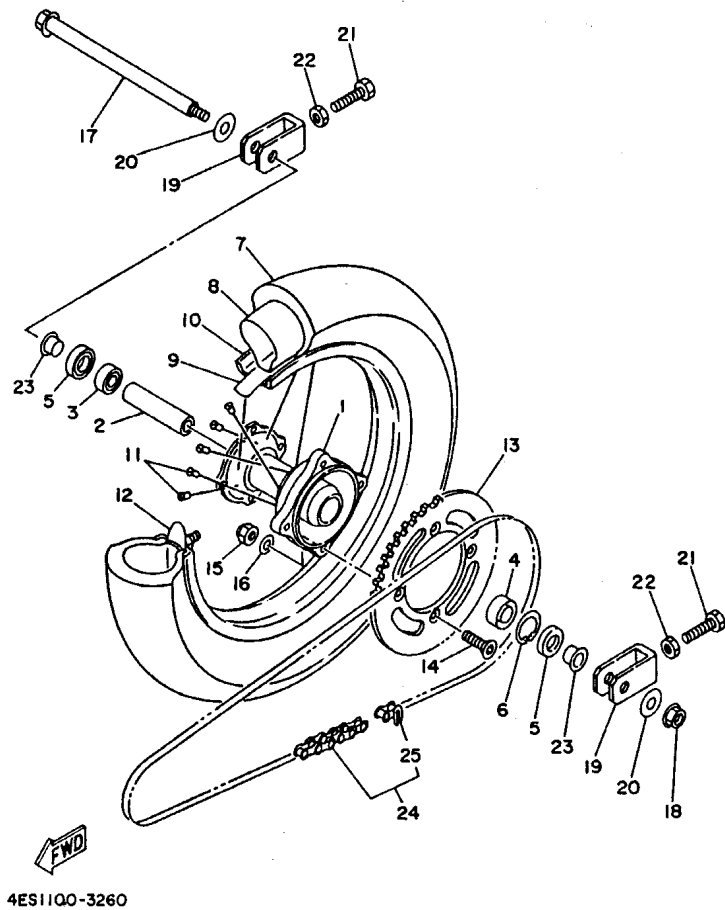
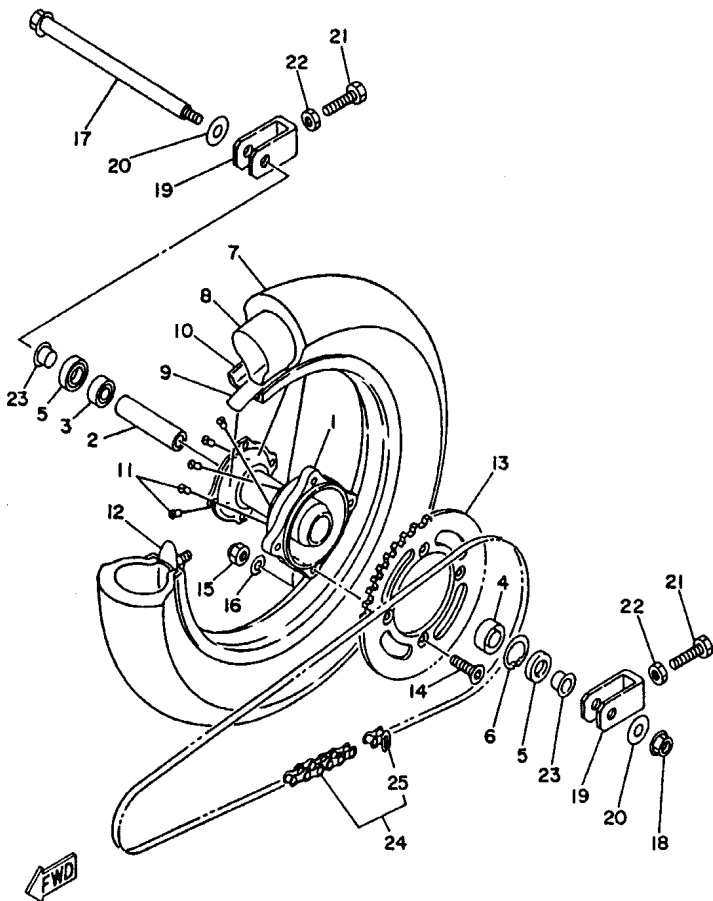

FIG. 26 REAR WHEEL

REF. NO.	PART NO.	DESCRIPTION	4ESA	4ESC	4LC8	4LCA	REMARKS
1	4ES-25311-00	HUB, REAR	1	1	1	1	
2	4ES-25383-00	COLLAR, WHEEL	1	1	1	1	
3	93306-00210	BEARING	1	1	1	1	
4	93306-20227	BEARING	1	1	1	1	
5	93102-20009	OIL SEAL	2	2	2	2	
6	99009-35500	CIRCLIP	1	1	1	1	
7	94109-1406C	TIRE (90/100-14 49M D752)	1				DUNLOP
	94109-147Y6	TIRE (90/100-14 49M K695)	1	1			DUNLOP EXCEPT FOR CAN
	94109-1606E	TIRE (90/100-16 52M D752)			1		DUNLOP
	94109-1602M	TIRE (90/100-16 52M K695)				1	DUNLOP
8	94208-14285	TUBE (80-90/100-14 TR4)	1	1			DUNLOP
	94209-16291	TUBE (90/100-16 TR-4)			1	1	DUNLOP
9	94308-14165	BAND, RIM (80-90/100-14)	1	1			DUNLOP
	94307-16171	BAND, RIM (70-90/100-16)			1	1	DUNLOP
10	94416-14529	RIM (1.60-14)	1	1			
	94418-16522	RIM (1.85-16)				1	1
11	4ES-25304-20	SPOKE SET, REAR	1	1			
	4LB-25304-00	SPOKE SET, REAR			1	1	
12	5X2-25394-00	SPACER, BEAD	1	1			
	1T2-25394-00	SPACER, BEAD			1	1	
13	4ES-25447-20	SPROCKET, DRIVEN (47T)	1	1	1	1	STD AFAM
	4ES-25446-00	SPROCKET, DRIVEN (46T)	1	1	1	1	AP
	4ES-25448-00	SPROCKET, DRIVEN (48T)	1	1	1	1	AP
14	90109-081G2	BOLT	4	4	4	4	
15	95617-08100	NUT, U	4	4	4	4	
16	90201-086P8	WASHER, PLATE	4	4	4	4	
17	4ES-25381-01	AXLE, WHEEL	1	1	1	1	

FIG. 26 REAR WHEEL



4ES1100-3260

REF. NO.	PART NO.	DESCRIPTION	4ESA	4ESC	4LC8	4LCA	REMARKS
18	95607-14200	NUT, SELF-LOCKING	1	1	1	1	
19	4ES-25388-00	PULLER, CHAIN 1	2	2	2	2	
20	90201-161R1	WASHER, PLATE	2	2	2	2	
21	90101-08475	BOLT	2	2	2	2	
22	95307-08700	NUT	2	2	2	2	
23	4ES-25383-10	COLLAR, WHEEL	2	2	2	2	
24	9Y581-58117	CHAIN (DID428G2 118L)	1	1			
	9Y581-58119	CHAIN (DID428G2 120L)			1		
	94581-58120	CHAIN (DID428G2 120L)				1	
25	94681-58001	JOINT, CHAIN	1	1	1	1	

FIG. 27 REAR BRAKE CALIPER

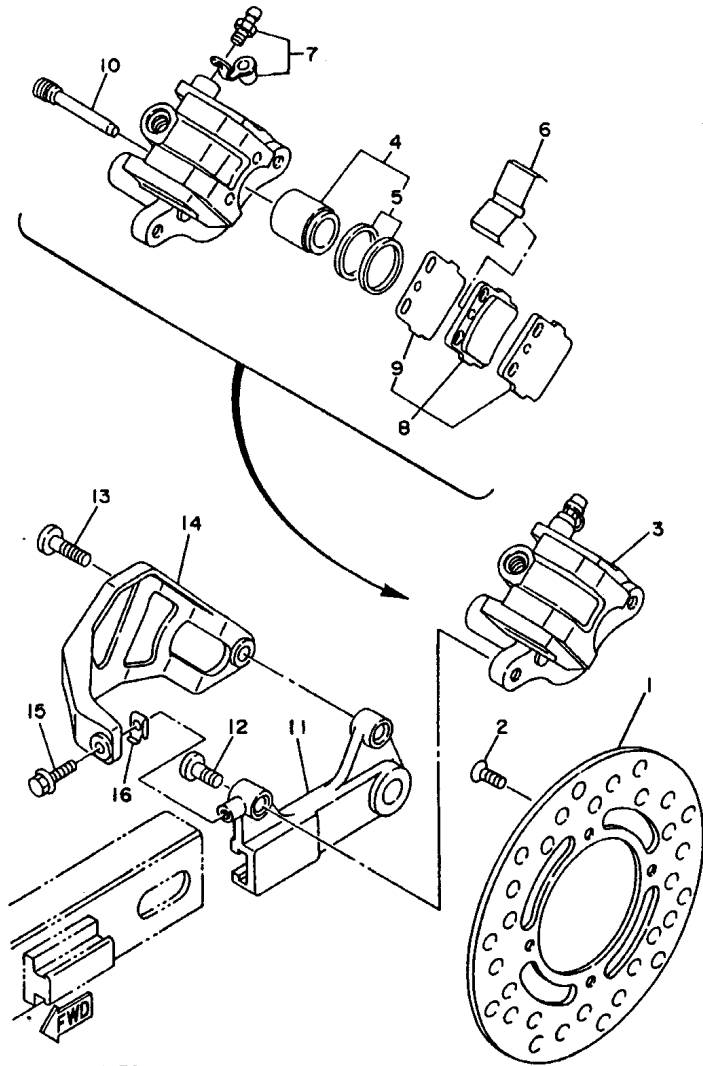

4ES1100-3270

REF. NO.	PART NO.	DESCRIPTION	4ESA	4ESC	4LCB	4LCA	REMARKS
1	4ES-2582W-00	DISC, REAR BRAKE 2	1	1	1	1	
2	90149-06327	SCREW	4	4	4	4	
3	4ES-2580W-00	CALIPER ASSY, REAR 2	1	1	1	1	
4	4ES-W0057-00	.PISTON ASSY, CALIPER	1	1	1	1	
5	4ES-W0047-00	..CALIPER SEAL KIT	1	1	1	1	
6	1UY-25919-51	..SUPPORT, PAD	1	1	1	1	
7	1UY-W0048-50	..BLEED SCREW KIT	1	1	1	1	
8	4ES-W0046-50	..BRAKE PAD KIT 2	1	1	1	1	
9	3GD-25827-00	..SHIM, CALIPER	1	1	1	1	
10	3GD-25933-00	..PIN, PAD	2	2	2	2	
11	4ES-25920-00	SUPT. BRKT. ASSY.	1	1	1	1	
12	90110-08096	BOLT, HEXAGON SOCKET HEAD	1	1	1	1	
13	90109-08718	BOLT	1	1	1	1	
14	4ES-27491-00	PROTECTOR	1	1	1	1	
15	95027-06012	BOLT, FLANGE	1	1	1	1	
16	4ES-27114-00	STOPPER, MAIN STAND	1	1	1	1	

FIG. 28 STEERING HANDLE. CABLE

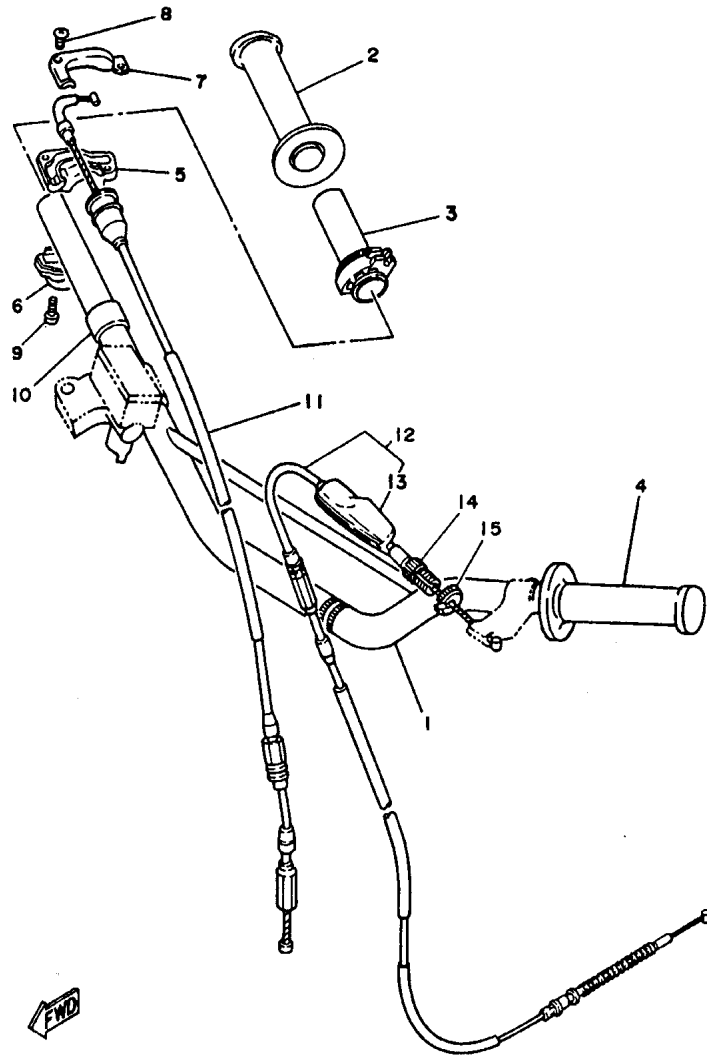

4ES6100-7280

REF. NO.	PART NO.	DESCRIPTION	4ESA	4ESC	4LC8	4LCA	REMARKS
1	4ES-26111-30	HANDLEBAR	1	1	1	1	
2	4GY-26242-00	GRIP (RIGHT)	1	1	1	1	
3	22W-26243-00	TUBE, THROTTLE GUIDE	1	1	1	1	
4	4GY-26241-00	GRIP (LEFT)	1	1	1	1	
5	5X2-26281-00	CAP, GRIP UPPER	1	1	1	1	
6	322-26282-00	CAP, GRIP LOWER	1	1	1	1	
7	5X2-2628H-01	CAP, WIRE	1	1	1	1	
8	98707-04012	SCREW, FLAT HEAD	2	2	2	2	
9	98507-05016	SCREW, PAN HEAD	2	2	2	2	
10	90387-227H7	COLLAR	1	1	1	1	
11	4ES-26311-01	CABLE, THROTTLE 1	1	1	1	1	
12	4ES-26335-11	CABLE, CLUTCH	1	1	1	1	
13	498-26372-00	.COVER, HANDLE LEVER 1	1	1	1	1	
14	90123-08046	BOLT	1	1	1	1	
15	90179-08148	NUT	1	1	1	1	

D6

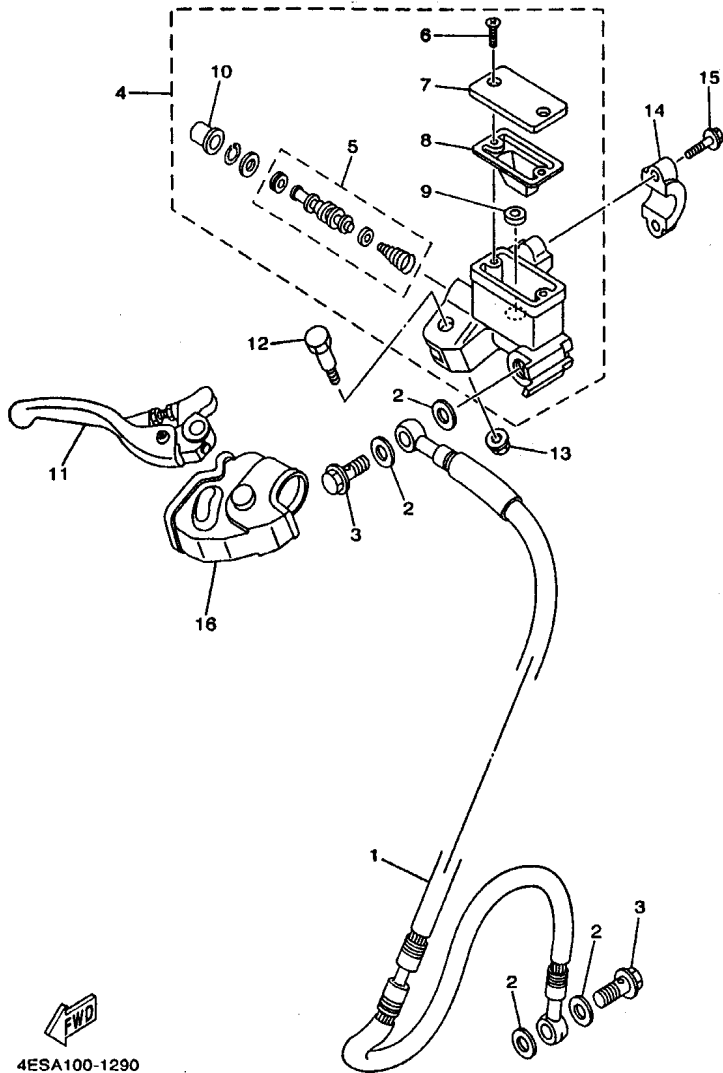

4ESA100-1290

FIG. 29 FRONT MASTER CYLINDER

REF. NO.	PART NO.	DESCRIPTION	4ESA	4ESC	4LCB	4LCA	REMARKS
1	4ES-25872-10	HOSE, BRAKE 1	1	1	1	1	
2	90201-10118	WASHER, PLATE	4	4	4	4	
3	90401-10168	BOLT, UNION	2	2	2	2	
4	5MV-W2587-00	MASTER CYLINDER SUB ASSY	1	1	1	1	
5	5MV-W0041-00	.CYLINDER KIT, MASTER	1	1	1	1	
6	98706-04012	.SCREW, FLAT HEAD	2	2	2	2	
7	5MV-25852-00	.CAP, RESERVOIR	1	1	1	1	
8	56A-25854-00	.DIAPHRAGM, RESERVOIR	1	1	1	1	
9	8CR-25715-00	.COVER 1	1	1	1	1	
10	5G2-25868-00	.BOOT, MASTER CYLINDER	1	1	1	1	
11	5MV-83922-00	LEVER 2	1	1	1	1	
12	5MV-2589F-00	BOLT, LEVER	1	1	1	1	
13	95701-06500	NUT, FLANGE	1	1	1	1	
14	5MV-25867-00	BRACKET, MASTER CYLINDER	1	1	1	1	
15	5MV-25833-00	BOLT, FITTING	2	2	2	2	
16	5MV-26372-00	COVER, HANDLE LEVER 1	1	1	1	1	

D7

FIG. 30 STAND. FOOTREST

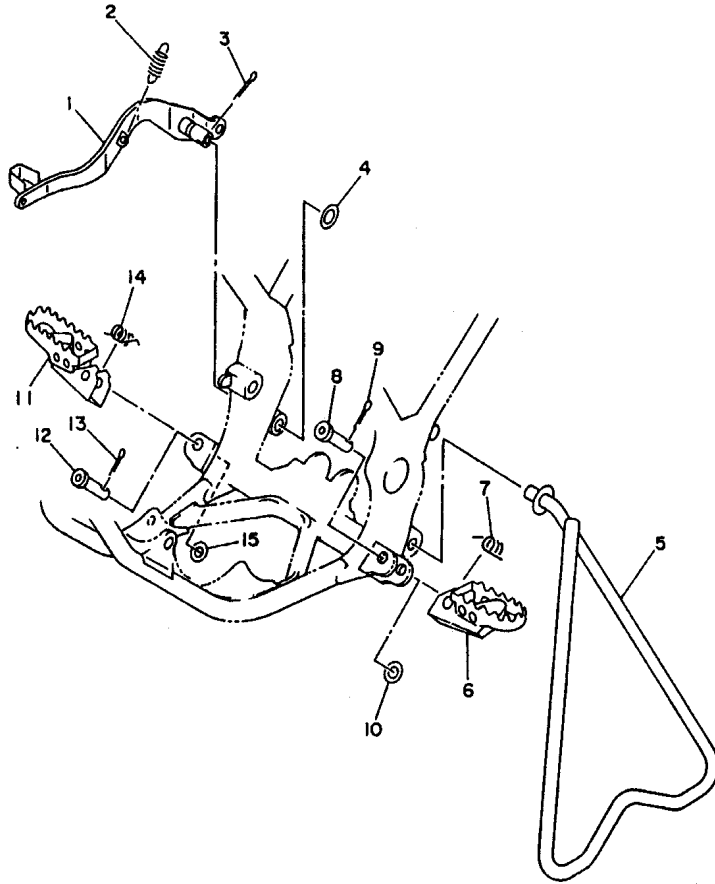

FWD
4ES1100-3300

REF. NO.	PART NO.	DESCRIPTION	4ESA	4ESC	4LCB	4LCA	REMARKS
1	4ES-27211-00	PEDAL, BRAKE	1	1	1	1	
2	90506-15480	SPRING, TENSION	1	1	1	1	
3	91401-20025	PIN, COTTER	1	1	1	1	
4	90201-15700	WASHER, PLATE	1	1	1	1	
5	4ES-27311-00	STAND, SIDE	1	1			
	4LB-27311-00	STAND, SIDE				1	
6	4DA-27411-00	FOOTREST 1	1	1	1	1	
7	90508-28777	SPRING, TORSION	1	1	1	1	
8	90240-10117	PIN, CLEVIS	1	1	1	1	
9	91401-25015	PIN, COTTER	1	1	1	1	
10	90201-10119	WASHER, PLATE	1	1	1	1	
11	4DA-27421-00	FOOTREST 2	1	1	1	1	
12	90240-10117	PIN, CLEVIS	1	1	1	1	
13	91401-25015	PIN, COTTER	1	1	1	1	
14	90508-28777	SPRING, TORSION	1	1	1	1	
15	90201-10119	WASHER, PLATE	1	1	1	1	

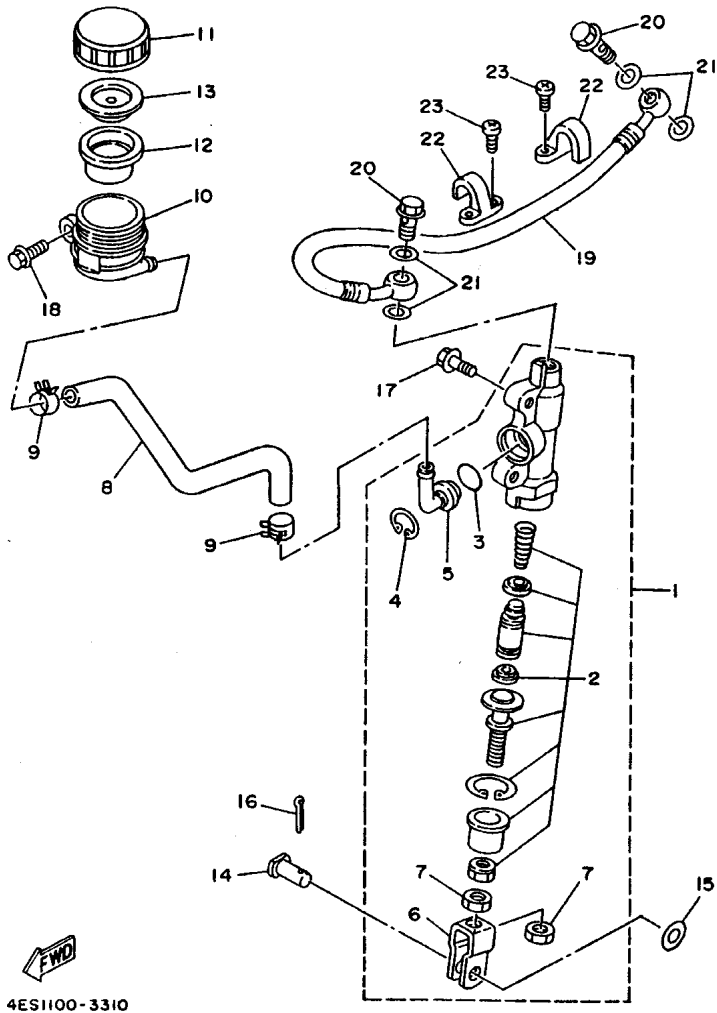

4ES1100-3310

FIG. 31 REAR MASTER CYLINDER

REF. NO.	PART NO.	DESCRIPTION	4ESA	4ESC	4LC8	4LCA	REMARKS
1	4ES-2583V-00	RR. MASTER CYLINDER ASSY.	1	1	1	1	
2	1FK-W0042-50	.CYLINDER KIT, MASTER	1	1	1	1	
3	93210-15620	.O-RING	1	1	1	1	
4	2VN-25866-00	.CIRCLIP	1	1	1	1	
5	2VN-2582A-50	.JOINT	1	1	1	1	
6	2YK-27222-00	.JOINT	1	1	1	1	
7	95307-08600	.NUT	2	2	2	2	
8	4ES-25895-00	HOSE, RESERVOIR	1	1	1	1	
9	90467-11044	CLIP	2	2	2	2	
10	4EW-25894-00	TANK, RESERVOIR	1	1	1	1	
11	3XP-25852-50	CAP, RESERVOIR	1	1	1	1	
12	2VN-25854-00	DIAPHRAGM, RESERVOIR	1	1	1	1	
13	2VN-25855-00	BUSH,DIAPHRAGM	1	1	1	1	
14	90240-08124	PIN, CLEVIS	1	1	1	1	
15	90201-08083	WASHER, PLATE	1	1	1	1	
16	91401-16012	PIN, COTTER	1	1	1	1	
17	95027-06016	BOLT, FLANGE	2	2	2	2	
18	95027-06012	BOLT, FLANGE	1	1	1	1	
19	4ES-25873-01	HOSE, BRAKE 2	1	1			
	4LB-25873-01	HOSE, BRAKE 2				1	
20	90401-10168	BOLT, UNION	1	1	1	1	
21	90201-10118	WASHER, PLATE	4	4	4	4	
22	2VM-25876-00	HOLDER, BRAKE HOSE 2	2	2	2	2	
23	97780-50510	SCREW, TAPPING	4	4	4	4	

D9

FIG. 36 OPTIONAL PARTS 1

REF. NO.	PART NO.	DESCRIPTION	4ESA	4ESC	4LCB	4LCA	REMARKS
1	4ES-11630-01	PISTON ASSY (STD)	1	1	1	1	
2	4ES-11631-01-A0	.PISTON (STD)	1	1	1	1	
	4ES-11631-01-B0	.PISTON (STD)	1	1	1	1	
	4ES-11631-01-C0	.PISTON (STD)	1	1	1	1	
	4ES-11631-01-D0	.PISTON (STD)	1	1	1	1	
3	43K-11611-00	.RING, PISTON	1	1	1	1	
4	4ES-11633-00	.PIN, PISTON	1	1	1	1	
5	93450-16115	.CIRCLIP	2	2	2	2	
6	4ES-11650-01	CONNECTING ROD ASSY	1	1	1	1	
7	4ES-11651-01	.ROD, CONNECTING	1	1	1	1	
8	93310-320T3	.BEARING	1	1	1	1	
9	2RA-11681-00	.PIN, CRANK 1	1	1	1	1	
10	90209-20159	.WASHER	2	2	2	2	
11	93310-214F8	.BEARING	1	1	1	1	KOYO

NUMERICAL INDEX

PARTNO.	GRID NO.	PARTNO.	GRID NO.	PARTNO.	GRID NO.	PARTNO.	GRID NO.	PARTNO.	GRID NO.	PARTNO.	GRID NO.
5MV-W0041-00	D - 7	31J-14103-00	B - 7	4ES-15421-01	B - 11	4XL-2153A-10	C - 12	4ES-22212-M0	D - 13	4ES-23170-10	C - 12
1FK-W0042-50	D - 9	10W-14104-00	B - 8	4ES-15451-00	B - 11	4ES-2153E-01	C - 5	3JD-22214-00	C - 9	4ES-23171-00	C - 11
4ES-W0045-20	D - 2	22W-14106-00	B - 7	4ES-15461-00	B - 11	25G-21575-00	C - 5	4ES-22214-00	C - 9	58T-23184-L0	C - 9
4ES-W0046-50	D - 5	23L-14107-25	B - 7	4ES-15620-00	B - 12	4ES-21611-10	C - 5	4ES-22216-00	C - 9	4V4-23194-L0	C - 12
4ES-W0047-00	D - 5	2X6-14112-25	B - 7	4ES-15621-00	B - 12	4ES-21642-00	C - 5	4ES-22251-00	C - 9	4ES-2331E-00	C - 12
4ES-W0047-10	D - 2	2X6-14112-30	B - 7	4ES-15641-00	B - 12	4ES-21711-00	C - 6	3XJ-22475-00	C - 8	4ES-23318-00	C - 12
1UY-W0048-50	D - 5	2X6-14112-35	B - 7	4ES-15651-00	B - 12	4EW-2172A-00	C - 6	4ES-23102-20	C - 11	4ES-23340-00	C - 12
4ES-W0057-00	D - 5	3R1-14115-00	B - 7	4ES-15660-00	B - 12	4ES-21721-00	C - 6	4LB-23102-20	C - 11	3XJ-23357-L0	C - 11
4ES-W0057-10	D - 2	2A6-14126-00	B - 8	4ES-15664-00	B - 12	4ES-2173E-50	C - 6	4ES-23103-20	C - 11		
5MV-W2587-00	D - 7	248-14131-00	B - 8	4ES-16111-00	B - 13	4ES-2173F-50	C - 6	4LB-23103-20	C - 11	4DA-23389-00	C - 10
4LC-11111-00	B - 2	3R1-14141-50	B - 7	4ES-16150-11	B - 13	4ES-2173L-40	C - 6	4ES-23110-00	C - 11	4ES-2339E-00	C - 10
4ES-11311-10	B - 2	3R1-14141-52	B - 7	4V0-16154-00	B - 13	4ES-21731-20	C - 6	4ES-23111-10	C - 11	1J7-23415-00	C - 10
4ES-11351-00	B - 2	3R1-14141-54	B - 7	21V-16321-00	B - 13	4ES-21732-00	C - 6			4ES-23435-00	C - 10
4ES-11400-02	B - 3	260-14142-30	B - 7	4ES-16321-00	B - 13	4ES-21735-00	C - 6	3JD-2312G-L0	C - 11	3SP-23441-00	C - 10
4ES-11412-00	B - 3	260-14142-32	B - 7	131-16324-00	B - 13	4DJ-2174A-00	C - 6			4ES-23485-20	C - 10
4ES-11422-00	B - 3	260-14142-35	B - 7	257-16324-00	B - 13	4ES-2174A-01	C - 7	4ES-23120-00	C - 11	4ES-24110-20	C - 13
43K-11611-00	B - 3	137-14143-58	B - 7	2TK-16351-00	B - 13	4LB-22110-01	C - 7	4ES-23125-00	C - 11	4EW-2412F-00	C - 13
		137-14143-60	B - 7	4ES-16356-00	B - 13	4ES-22129-00	C - 7	4ES-23136-20	C - 11	24X-24144-00	C - 13
4ES-11630-01	D - 14	137-14143-62	B - 7	2RA-16357-00	B - 13	4ES-22151-10	C - 7	4ES-2314F-00	C - 12	22W-24181-00	C - 6
4ES-11631-01-A0	B - 3	39K-14153-00	B - 7	37F-16371-01	B - 13	4ES-2217A-00	C - 7	4ES-2314H-L1	C - 12	3Y0-24183-00	C - 13
		2A6-14158-00	B - 8	4ES-16381-00	B - 13	4ES-2217F-00	C - 8	4ES-2314J-L0	C - 12	4ES-24244-10	C - 13
4ES-11631-01-B0	B - 3	3X3-14169-00	B - 7	4ES-17121-01	B - 14	30X-22178-00	C - 4	4ES-23141-40	C - 11	4ES-24311-10	C - 13
		3SB-14171-00	B - 8	4ES-17131-00	B - 14	4ES-22178-00	C - 4			4DP-24500-00	C - 13
4ES-11631-01-C0	B - 3	304-14184-00	B - 7	4ES-17151-00	B - 14	4V4-22184-00	C - 4			4X8-24512-00	C - 13
		314-14185-00	B - 7	4ES-17161-00	B - 14	39K-22199-00	C - 7	4ES-23141-50	D - 13	3AJ-24523-00	C - 13
4ES-11631-01-D0	B - 3	127-14186-00	B - 7	4ES-17211-01	B - 14	4ES-22201-30	C - 9	4ES-23141-60	D - 13	3AJ-24534-00	C - 13
		10V-14196-00	B - 7	4ES-17221-01	B - 14	4ES-22201-40	C - 9	4LB-23141-10	C - 11	5X7-24611-01	C - 13
4ES-11633-00	B - 3	3JN-14196-00	B - 8	4ES-17231-01	B - 14	4ES-22201-50	C - 9			5X7-24612-00	C - 13
		3Y1-14197-00	B - 8	4ES-17241-00	B - 14	4ES-22201-60	C - 9	3GM-23142-00	C - 11	4ES-24728-00	C - 14
4ES-11650-01	D - 14	4ES-14411-01	B - 6	4ES-17251-00	B - 14	4GT-22201-10	C - 9			4ES-24731-50	C - 14
4ES-11651-01	B - 3	4ES-14417-00	B - 6	4ES-17261-01	B - 14	4LB-22201-50	C - 9	4ES-23142-00	C - 11	4ES-24770-50	C - 14
		4ES-14451-00	B - 6	4ES-17411-01	B - 14	4LB-22201-60	C - 9			4ES-25104-20	C - 15
2RA-11681-00	B - 3	4ES-14453-00	B - 6	4ES-17421-00	B - 14	4ES-22210-C0	C - 9	4ES-23142-00	C - 11	4LB-25104-00	C - 15
		4ES-14458-00	B - 6	164-17427-00-06	B - 14	4ES-22210-D0	C - 9	4ES-23144-00	C - 11	4ES-25111-00	C - 15
4BA-12422-00	B - 4	4ES-14459-00	B - 6	164-17427-00-08	B - 14	4ES-22210-E0	C - 9			22W-25181-01	C - 7
4BA-12428-00	B - 4	4ES-14462-00	B - 6	164-17427-00-10	B - 14	4ES-22210-F0	C - 9	4ES-23145-00	C - 11	4ES-25181-00	C - 15
36F-12450-00	B - 4	4ES-14610-10	B - 9	4ES-18101-00	C - 3	4GT-22210-40	C - 9			4ES-25183-10	C - 15
4ES-12459-00	B - 4	17W-14615-00	B - 9	2HF-18110-01	C - 3	4LB-22210-70	C - 9	5K5-23149-00	C - 11	1T1-25194-00	C - 15
4ES-12461-10	B - 5	4ES-1469A-00	B - 9	4BA-18140-00	C - 3	4LB-22210-80	C - 9			4ES-25304-20	D - 3
5HD-12462-00	B - 5	4ES-14753-10	B - 9	4ES-18511-02	C - 2	4ES-22212-F0	C - 9	4A1-23156-00	C - 11	4LB-25304-00	D - 3
22W-12463-00	B - 5	56S-14771-00	B - 9	5R2-18512-00	C - 2					4ES-25311-00	D - 3
4ES-12481-00	B - 5	58T-1490J-00	B - 7	4ES-18513-01	C - 2	4ES-22212-G0	C - 9	2HH-23158-L0	C - 11	4ES-25381-01	D - 3
4ES-12482-00	B - 5	25G-14937-00	B - 8	4BA-18531-00	C - 2					4ES-25383-00	D - 3
4ES-13565-00	B - 6	4ES-15111-00	B - 10	4BA-18535-00	C - 2	4ES-22212-H0	C - 9	4ES-2316A-10	C - 11	4ES-25383-10	D - 4
4ES-13610-00	B - 6	4ES-15121-02	B - 10	4ES-18540-00	C - 2					4ES-25388-00	D - 4
4ES-13613-00	B - 6	3Y1-15363-00	B - 11	4ES-21110-02-P0	C - 4	4ES-22212-J0	D - 13	4LB-2316A-20	C - 11	1T2-25394-00	D - 3
4ES-13616-00	B - 6	120-15371-00	B - 10	4ES-21123-00-P2	C - 4	4ES-22212-K0	C - 9			5X2-25394-00	D - 3
4ES-14101-10	B - 7	4ES-15411-00	B - 11	4ES-21511-20	C - 5						

NUMERICAL INDEX

PARTNO.	GRID NO.	PARTNO.	GRID NO.	PARTNO.	GRID NO.	PARTNO.	GRID NO.	PARTNO.	GRID NO.	PARTNO.	GRID NO.
4ES-25446-00	D-3	5MV-26372-00	D-7	90119-06217	C-8	90208-12015	B-13	90480-15528	B-5	93310-320T3	B-3
4ES-25447-20	D-3	4ES-27114-00	D-5	90119-06225	C-14	90209-06096	B-6	90480-16561	B-9		D-14
4ES-25448-00	D-3	4ES-27211-00	D-8	90122-06038	B-6	90209-06187	C-5	90480-18411	B-9	93315-11206	B-13
8CR-25715-00	D-7	2YK-27222-00	D-9	90123-08046	D-6	90209-20159	B-3	90480-18549	C-13	93315-21455	C-7
4ES-2580T-20	D-2	4ES-27311-00	D-8	90149-06011	C-13		D-14	90501-12081	B-12	93315-31502	B-14
4ES-2580W-00	D-5	4LB-27311-00	D-8	90149-06327	D-2	90240-08124	D-9	90501-20735	B-13	93317-11245	B-14
2VN-2582A-50	D-9	4DA-27411-00	D-8		D-5	90240-10117	D-8	90506-15480	D-8	93317-21746	C-7
4ES-2582T-00	D-2	4DA-27421-00	D-8	90157-05079	C-10	90250-06013	C-2	90507-20030	B-9	93317-31771	C-7
4ES-2582W-00	D-5	4ES-27491-00	D-5	90157-06071	B-14	90267-40077	B-6	90508-242A6	C-3		C-8
47X-25824-00	D-2	51L-28371-00	C-13	90176-08026	B-2	90280-03017	B-3	90508-26750	B-12	93332-00079	C-10
51L-25825-00	D-2	4KJ-82310-10	D-12	90179-08148	D-6	90282-05001	B-13	90508-28777	D-8	93399-99921	C-8
3GD-25827-00	D-5	1M1-82370-30	D-12	90179-08299	B-2	90338-10150	C-8	90508-32553	C-3	93410-20038	B-14
4ES-2583V-00	D-9	4ES-82509-00	D-11	90179-12659	B-13	90380-10218	C-7	90793-20136	B-2	93430-08007	B-12
5MV-25833-00	D-7	38V-82911-00	D-11	90179-22412	C-10	90380-12219	C-7	91401-16012	D-9	93440-15012	B-14
34X-25845-00	D-2	38V-82913-00	D-11	90179-25033	C-10	90381-12091	C-8	91401-20025	D-8	93440-17064	B-14
3XP-25852-50	D-9	4GY-83912-00	D-11	90183-06023	C-6	90385-17042	C-7	91401-25015	D-8	93440-30113	C-8
5MV-25852-00	D-7	5MV-83922-00	D-7	90183-06069	C-6	90387-060A3	C-4	92907-03100	B-6	93450-16115	B-3
2VN-25854-00	D-9	437-83936-01	B-5	90185-10110	C-9	90387-06027	C-13	92907-04100	B-7		D-14
56A-25854-00	D-7		D-10	90185-12046	C-15	90387-0614M	B-5	92907-04600	B-6	93503-16003	B-13
2VN-25855-00	D-9		D-11	90185-12119	C-8	90387-062M9	C-6	92907-06600	D-10	93507-32009	B-12
2VN-25866-00	D-9	437-83936-11	D-12	90201-047A2	B-6	90387-062X0	C-7	92907-10600	C-9	93603-22028	B-4
5MV-25867-00	D-7	22W-83976-00	D-11	90201-060A3	B-9	90387-063G3	B-9	93101-12173	C-3	93822-12012	B-15
5G2-25868-00	D-7	4ES-85510-20	D-10	90201-06060	B-12	90387-064X4	C-5	93101-17062	C-7	93822-13024	B-15
4ES-25872-10	D-7	4ES-85540-20	D-12		B-14	90387-103X9	C-8		C-8	93822-14037	B-14
4ES-25873-01	D-9	2A7-85546-00	D-12	90201-06071	B-5	90387-105L0	B-9	93102-12224	B-13		B-15
4LB-25873-01	D-9	4ES-85550-10	D-10		C-13	90387-1200U	C-7	93102-17263	B-12	93822-15065	B-15
2VM-25876-00	D-9	9Y581-58117	D-4	90201-080E2	C-4	90387-124H0	C-15	93102-20009	D-3	94107-1706B	C-15
5MV-2589F-00	D-7	9Y581-58119	D-4	90201-08083	D-9	90387-126Y7	C-3	93102-20143	B-14	94107-177Y5	C-15
4EW-25894-00	D-9	90101-08475	D-4	90201-08087	B-2	90387-127J7	C-7	93102-20447	B-3	94107-1902L	C-15
4ES-25895-00	D-9	90101-12755	C-8	90201-081R9	C-4	90387-127J8	C-7	93103-10147	B-4	94107-1906D	C-15
1UY-25919-51	D-5	90105-08211	D-2	90201-08512	B-4	90387-20498	B-13	93103-28126	B-3	94109-1406C	D-3
56A-25919-00	D-2	90105-08310	C-7	90201-086P8	D-3	90387-227H7	D-6	93106-20031	C-15	94109-147Y6	D-3
56A-25919-10	D-2	90105-10582	C-7	90201-10118	D-7	90401-10168	D-7	93109-17071	C-7	94109-1602M	D-3
4ES-25920-00	D-5	90105-10614	C-9		D-9		D-9	93210-15620	D-9	94109-1606E	D-3
56A-25926-00	D-2	90105-12382	C-7	90201-10119	D-8	90430-06166	B-4	93210-18288	B-7	94207-17284	C-15
3GD-25933-00	D-5	90109-067F4	C-6	90201-10591	D-10	90430-08119	B-11	93210-19123	B-11	94207-19290	C-15
5R2-25937-00	D-2	90109-06799	D-11	90201-12362	C-15	90445-09100	C-13	93210-371A9	B-9	94208-14285	D-3
56A-25937-00	D-2	90109-081G2	D-3	90201-124F8	B-12	90445-09220	C-13	93210-56459	B-2	94209-16291	D-3
4ES-26111-30	D-6	90109-08718	D-5	90201-124G9	C-7	90446-07349	B-10	93210-84724	B-2	94307-16171	D-3
4GY-26241-00	D-6	90109-10729	C-9	90201-12631	B-12	90450-28014	B-5	93306-00210	D-3	94307-17166	C-15
4GY-26242-00	D-6	90110-08096	D-5	90201-12749	C-8	90450-45075	B-6	93306-20120	C-15	94307-19170	C-15
22W-26243-00	D-6	90116-08318	B-2	90201-15700	D-8	90450-99064	B-6	93306-20227	D-3	94308-14165	D-3
5X2-2628H-01	D-6	90116-08388	B-2	90201-161R1	D-4	90460-51059	B-6	93306-20333	B-14	94414-17530	C-15
5X2-26281-00	D-6	90116-08394	B-2	90201-176L4	B-12	90464-16039	B-6	93306-20401	B-14	94414-19521	C-15
322-26282-00	D-6	90119-05001	B-13	90201-203E7	B-14	90467-08002	B-5	93306-20438	B-3	94416-14529	D-3
4ES-26311-01	D-6	90119-06063	C-5	90201-256K5	C-10	90467-10008	C-13	93306-30421	B-3	94418-18522	D-3
4ES-26335-11	D-6	90119-06118	C-4	90201-33299	B-9	90467-11044	D-9	93310-214F8	B-3	94581-58120	D-4
498-26372-00	D-6	90119-06185	C-5	90202-05193	C-13	90468-23194	B-12		D-14	94681-58001	D-4

NUMERICAL INDEX

PARTNO.	GRID NO.	PARTNO.	GRID NO.	PARTNO.	GRID NO.	PARTNO.	GRID NO.	PARTNO.	GRID NO.
94702-00368	B - 2	98507-03008	B - 6						
95021-10040	C - 12	98507-04018	B - 7						
95024-06010	C - 12	98507-05016	D - 6						
95027-06012	B - 9	98507-06016	D - 10						
	B - 12	98507-06030	B - 11						
	C - 10	98507-06040	B - 10						
	C - 14	98507-06050	B - 10						
	D - 5	98507-06060	B - 10						
	D - 9	98706-04012	D - 7						
95027-06014	C - 7	98707-04012	D - 6						
95027-06016	C - 5	98707-06025	C - 13						
	C - 6	99001-07600	B - 4						
	C - 12	99001-10600	C - 3						
	C - 13	99009-10400	C - 2						
	D - 9	99009-12400	B - 12						
	D - 12	99009-18400	B - 15						
95027-06020	B - 6	99009-35500	D - 3						
95027-06025	B - 4	99244-00140	C - 8						
	B - 9	99530-10014	B - 10						
95027-06030	B - 5		B - 11						
	B - 11	99530-10114	B - 2						
	C - 13								
95027-06040	B - 11								
95027-08012	C - 4								
95027-08020	C - 4								
95027-08030	C - 10								
95027-08080	B - 11								
95307-08600	D - 9								
95307-08700	D - 4								
95317-10600	D - 10								
95807-06100	D - 11								
95607-08200	C - 4								
	C - 7								
95607-10200	C - 7								
95607-12200	C - 8								
95607-14200	D - 4								
95617-08100	D - 3								
95617-12100	C - 7								
95701-06500	D - 7								
95807-08035	C - 10								
95817-08125	C - 4								
95817-08135	C - 4								
95827-06060	B - 4								
97007-05016	D - 11								
97027-06020	C - 3								
97707-50014	B - 6								
97780-50510	D - 9								
97801-03008	C - 13								